

**I LITEC****Traversen mit Endplatte**

FX25SA	10
FX25SA	12
FX30SA	14
FX30SA	16
TX25SA	18
TX25SA	20
TX30SA	22
TX30SA	24
QX25SA	26
QX25SA	28
QX30SA	30
QX30SA	32
QX40SA	34
QX40SA	36
TH30SA	38
TH30SA	40
QH30SA	42
QH30SA	44
QH40SA	46
QH40SA	48
RH40SA	50
RH40SA	52

**Konstruktionssoftware**

LiteCad Evolution	54
-------------------	----

**Libera-System**

LIBERA FL52	60
LIBERA FL52	62
LIBERA FL76	64
LIBERA FL76	66
LIBERA FL105	68
LIBERA FL105	70

**High-Load-Gabeltraversen**

RF40	76
RF40	78
QL40A	80
QL40A	82
QL52A	84
QL52A	86
QL76A	88
QL76A	90
QL85A	92
RL76A	94
RL76A	96
RL105A	98
RL105A	100
MyT Virtue	102
MyT	104
MyT Steroid	106
MyT Folding Steroid	108

**Pre-Rig Transportsystem**

PR60	114
PR60	116
PR60 Revolution	118
PR60 Revolution	120

**Bogetraversen und Kreissegmente**

End Plated Circles Trusses	126
High Load Circles Trusses	128

**Traversen Tower**

Towerlift 3	134
Unitower	136
Varitower 3	138
Maxitower MT40	140
Maxitower MT52	142
Maxitower MT52HD	144
Maxitower MT63	146
Maxitower MT76	148
Maxitower MT85	150



## Strutture

---

We design and manufacture industry standard aluminium truss systems & self-standing structures for entertainment, corporate, film/TV, concert touring, theme park and architectural applications.

All of your trussing and rigging needs are met thanks to our cutting edge technology, innovative designs, extensive product portfolio and global network distribution.

## Soluzioni

---

Highly qualified staff and an experienced engineering department consistently maintain a strong focus on new product design and development. Our in-house R&D department also offers custom and bespoke solutions to satisfy the needs of every project.

We provide our clients with knowledge and expertise – from initial concept to installation – to ensure the realization of safe, simple and easy to assemble solutions.

## Sinergie

---

To complete our trussing line, we offer a wide range of selected rigging products from third parties like: electric chain hoists, controllers, load cell, stage deck rigging hardware and accessories. All products comply with the highest standards of quality and safety, as we firmly believe high quality equals safety.

We've always been on the front line in sharing our know-how throughout the industry with the organization of training for professionals.

[www.litectruss.com](http://www.litectruss.com)

Follow us: [@litectrussing](https://www.instagram.com/litectrussing)





## Certifications

---

The LITEC products are manufactured according to ISO EN 1090-1 and 1090-3. There are different levels of quality when talking about aluminium trusses. There is the quality of the raw material, the quality of welding and the quality on the manufacturing process. Products have to comply with all the relevant international standards and they are tested and certified by the most respectable certification institutes. High quality equals safety. This is guaranteed not only through certificates, but also with common sense and deep knowledge of engineers and installers. The product needs to be calculated and certified through rigorous calculation reports and installation must be tested by a qualified engineer.

The Standards that are commonly used for the technical evaluation of a product refer to normative codes issued and recognized at a national and international level. Among these we can mention ANSI, BS, EN, ISO, DIN. Each of these outlines a different calculation approach, still leading to similar results.

LITEC's products and processes are certified by the following bodies:

**TÜV Süd** One of the world's leading organizations that supplies technical services and certifies the quality of processes and products.

**TÜV Nord** International provider of security, inspection and certification services in the fields of industry, mobility, natural resources, aerospace, training and IT.

**GSI SLV München (Schweißtechnische Lehr – und Versuchsanstalt)** They certify that welding quality control process is carried out in accordance with German standard DIN V 4113-3. LITEC is certified at class C, the most demanding of the certification grades, corresponding to the highest levels of quality.

**DVS Zert** They certify the process of welding according to the European and international standard EN ISO 3834-2, and provide certified welders' licenses. DVS Zert is ANBCC (Authorized National Body for Company Certification) for Germany, within EWF (European Welding Federation) and IIW (International Institute of Welding).

**DIBt (Deutsches Institut für Bautechnik)** They are the Center of Competence in Civil Engineering by certifying the resistance of welding between aluminium extruded profiles and die-cast end plates. They are a member of EOTA (European Organisation for Technical Approvals) and other national and international organisations.

**University of Padua – Department of Civil, Environmental and Architectural Engineering** They carry out 'Stress Tests' on trussing products.

**Iuav University of Venice – Department of Architectural Construction** They carry out 'Stress Tests' on trussing products.







# Trusses



## Quality

LITEC offers a vast and complete range of trusses, which includes the series with end plates, the truss line provided with conical connection, the LIBERA System and the High Load Trusses with forked connections, in order to meet the needs of operators in various different sectors. Trusses are aesthetically pleasing, light and robust and are used where structures have to be built for hanging lights, equipment, false ceiling, etc. To provide the right solution for every situation, with the most suitable product.

### LIBERA STAR System Trusses

---

Libera FL52

Libera FL76

Libera FL105

### END PLATED Light Duty Trusses

---

FX25SA

FX30SA

TX25SA

TX30SA

QX25SA

QX30SA

QX40SA

TH30SA

QH30SA

QH40SA

RH40SA

◆ LiteCAD Evolution

### FORK High Load Trusses

---

RF40

QL40A

QL52A

QL76A

QL85A

RL76A

RL105A

MyT Virtue

MyT

MyT Steriod

MyT Folding Steroid





# END PLATED

## Light Duty Trusses

### Reliability

---

The end-plated truss line stands out for its design, durability and reliability. Strengthened by a dual connection system of spigots or bolts, represents a benchmark for the installations sector.

The end plate guarantees relevant benefits:

- Greater twist resistance
- Minimal eccentricity
- Absolute compatibility between trusses.

In addition, when end-plated trusses are loaded in a van, they allow to use the room inside them, thus exploiting space at the best.

# FX25SA

## Anti-torsion



Flat section aluminium truss with 25 cm long sides. This is the smallest of our flat, end-plated trusses. Internal diagonal braces are made using 14 mm extruded aluminium, which helps to keep the visual profile of the truss to a minimum. Also suitable for use in tight spaces.

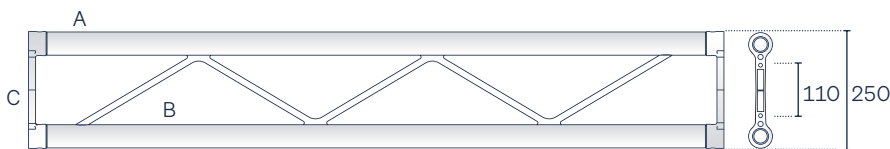

### Corners and fittings

code	cm	kg
FX25C2	25 x 5 x 5	1.2
FX25C4	25 x 25 x 5	3.3
FU25K2	25 x 5 x 5	1.3
FU25K4	25 x 25 x 5	3.4
FX25SAACS	25 x 12.5 x 5	1.7
FX25SAL2045P	50 x 50 x 5	2.0
FX25SAL2045V	50 x 50 x 25	3.0
FX25SAL2060P	50 x 50 x 5	2.7
FX25SAL2060V	50 x 50 x 25	3.3
FX25SAL2090P	50 x 50 x 5	1.7
FX25SAL2090V	50 x 50 x 25	1.8
FX25SAL2120P	50 x 50 x 5	1.7
FX25SAL2120V	50 x 50 x 25	1.9
FX25SAL2135P	50 x 50 x 5	2.1
FX25SAL2135V	50 x 50 x 25	1.9
FX25SAL3LP	50 x 50 x 50	2.5
FX25SAL3LV	50 x 50 x 50	2.7
FX25SAL3RP	50 x 50 x 50	2.7
FX25SAL3RV	50 x 50 x 50	2.7
FX25SAT3NP	50 x 50 x 5	2.1
FX25SAT3NV	25 x 50 x 50	2.1
FX25SAT4NP	50 x 50 x 50	3.0
FX25SAT4NV	50 x 50 x 50	2.7
FX25SAX4NP	50 x 50 x 55	2.1
FX25SAX4NV	50 x 50 x 25	2.4
FX25SAAACL	25 x 25 x 5	4.1

### Chords A

Extruded tube  $\varnothing$  50.8 x 1.6 mm  
EN AW – 6060 T66

### Diagonals B

Extruded tube  $\varnothing$  14 x 1.5 mm  
EN AW – 6060 T6

### Ends C

Aluminium casting plate  
EN AC – 42200 KT6

### Connection systems

QXFC: quick-fit kit  
QXSM8: bolt connection kit

### Linear elements

code	cm	kg
FX25SA012M5	25 x 5 x 12.5	0.8
FX25SA025	25 x 5 x 25	1.0
FX25SA050	25 x 5 x 50	1.5
FX25SA100	25 x 5 x 100	2.3
FX25SA150	25 x 5 x 150	3.0
FX25SA200	25 x 5 x 200	3.9
FX25SA250	25 x 5 x 250	4.6
FX25SA300	25 x 5 x 300	5.4
FX25SA350	25 x 5 x 350	6.2
FX25SA400	25 x 5 x 400	7.0

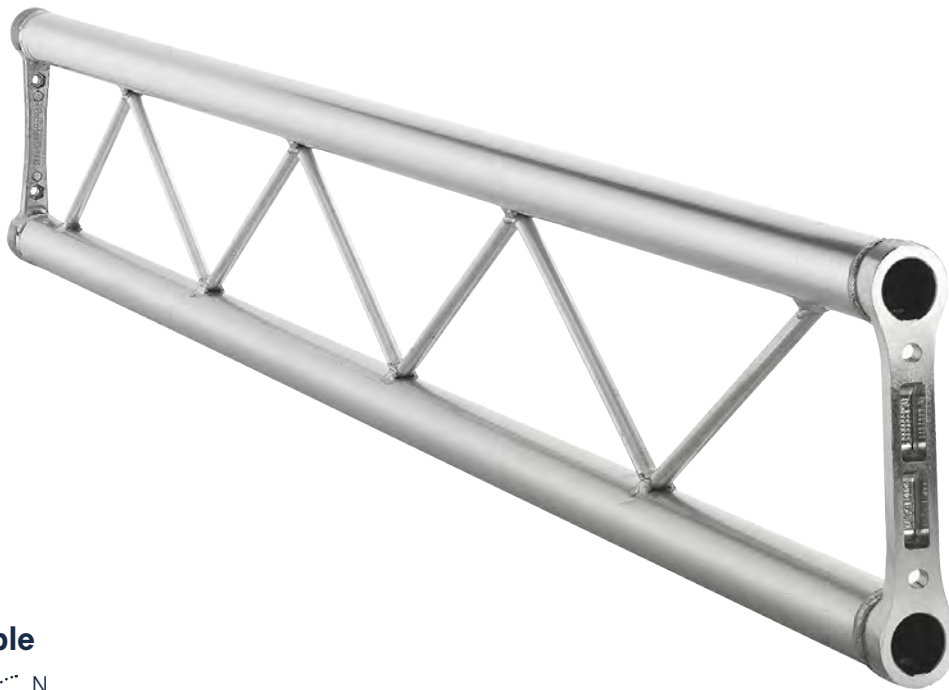

### Axial load table



H m	Awt kg
2	193
3	85
4	48

Load table has been prepared in accordance with UNI ENV 1999-1-1 (Eurocode 9). When calculating the allowable loads it is assumed that the load is suspended from the bottom chord and the truss is supported from the top chord at each end.

The values shown in the table are the allowable static loads that can be applied to the truss. This is the live load or the payload.

The self weight of the truss has been taken into account when calculating the values in the table.

It should be noted that this are idealised loading conditions and the User shall re-analyze the truss for the loading conditions which prevail for the application being considered.

### Load table / Spigot connection



SPAN	Unif. distributed load			Centre point load			Third point load			Quarter point load			Fifth point load		
	Point load	Full load	Central deflection	Point load	Full load	Central deflection	Point load	Full load	Central deflection	Point load	Full load	Central deflection	Point load	Full load	Central deflection
m	kg/m	kg	mm	kg	kg	mm	kg	kg	mm	kg	kg	mm	kg	kg	mm
1	248	248	0	248	248	0	124	248	0	83	248	0	62	248	0
2	123	246	1	237	237	1	123	246	1	82	246	1	61	246	1
3	81	244	2	126	126	2	94	189	3	63	189	2	52	210	2
4	27	109	3	54	54	2	41	82	3	27	82	3	23	91	3
5	11	53	3	26	26	2	20	40	3	13	40	3	11	44	3
6	4	26	3	13	13	2	10	20	3	7	20	3	5	22	3

# FX25SA

## System

To further enhance the standard products, Litec offers a wide range of corners, connections and accessories useful for many different applications and needs. "Quick connect" or "nult & bolt connect". End-plated trusses allow to use two different systems of connection. The quick-fit system is certainly the most wide-spread and mainly used when the steucture is frequently assembled and dismantled. In case of permanent installations, on the order hand, a more aconomical bolt connection system may be used. Our plate is made in such a way that bolts may be completely inserted so that there are no edges or external protuberances which could damage canvases or other fabrics or which might simply be unaesthetic on certain structures.

## Connections



### KSG

Extruded tube Ø 50.8x1.6 mm  
EN AW - 6060 T66



### KCP

R-spring,  
set of 100

### KSP

Steel pin,  
set of 10



### K370-4

Half truss spigot + 1 steel pin  
+ 1 R-spring (not for Dado)



### KSFH

Threaded pin, set of 12



### KCFS

Kit for vert. connec incl.  
bolts, spigots and accessories



### FXFC

Quick connection set



### FUKFC

4 special steel half pigots with  
screws for Heavy Duty Dado  
set of 100



### FXSM8\*

Bolt connection set for 25 series



### KSN

Threaded pin, set of 10



### FXCFC

2 special steel half spigots with  
screws for Light Duty Dado

### \* Achtung!

werden nur die Schraubverbinder  
eingesetzt, verringert sich die  
Tragkraft um 50%

## Accessories



### FX25SAACL

ST 25 cm. flat - Clamp module  
long



### FX25SAACS

ST 25 cm. flat - Clamp module  
short



### TZ30K01

Assembly tool for half-spigot in  
25 & 29cm side trusses with  
Heavy Duty Dado



### TZ30C01

Assembly tool for half-spigot in  
25 & 29cm side trusses with  
Light Duty Dado



### CL2D50

Transport clip.  
Plastic casting for truss stacking.  
Fits 48 - 51 mm tube



### FP25

Universal 25 cm truss floor plate  
(25x25 cm)



### FP25M

Universal 25 cm truss floor plate  
(50x50 cm)

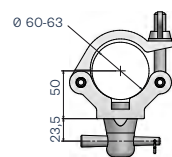

### LT C370

Truss clamp ALI6063  
1/2 spigot swl 500kg

## Dados, Corners & fittings



**FX25SAL2045P**  
ST 25 cm. flat - 2 way 45° corner horizontal



**FX25SAL2045V**  
ST 25 cm. flat - 2 way 45° corner vertical



**FX25SAL2060P**  
ST 25 cm. flat - 2 way 60° corner horizontal



**FX25SAL2060V**  
ST 25 cm. flat - 2 way 60° corner vertical



**FX25SAL2090P**  
ST 25 cm. flat - 2 way 90° corner horizontal



**FX25SAL2090V**  
ST 25 cm. flat - 2 way 90° corner vertical



**FX25SAL2120P**  
ST 25 cm. flat - 2 way 120° corner horizontal



**FX25SAL2120V**  
ST 25 cm. flat - 2 way 120° corner vertical



**FX25SAL2135P**  
ST 25 cm. flat - 2 way 135° corner horizontal



**FX25SAL2135V**  
ST 25 cm. flat - 2 way 135° corner vertical



**FX25SAL3LP**  
ST 25 cm. flat - 3 way corner left horizontal



**FX25SAL3RP**  
ST 25 cm. flat - 3 way corner right horizontal



**FX25SAL3LV**  
ST 25 cm. flat - 3 way corner left vertical



**FX25SAL3RV**  
ST 25 cm. flat - 3 way corner right vertical



**FX25SAT3NP**  
ST 25 cm. flat - 3 way tee horizontal



**FX25SAT3NV**  
ST 25 cm. flat - 3 way tee vertical



**FX25SAT4NP**  
ST 25 cm. flat - 4 way tee horizontal



**FX25SAT4NV**  
ST 25 cm. flat - 4 way tee vertical



**FX25SAX4NP**  
ST 29 cm. flat - 4 way cross horizontal



**FX25SAX4NV**  
ST 29 cm. flat - 4 way cross vertical

## Light duty Dado



**FX25C2**  
DADO 4 way flat corner (2 nodules) C2 is the DADO version for flat section



**FX25C4**  
DADO 6 way flat corner (4 nodules) C4 is the DADO version for square and flat section structures

## Heavy duty Dado



**FU25K2**  
DADO 4 way flat corner (2 nodules) K2 is the HD DADO version for flat version



**FU25K4**  
DADO 6 way flat corner (4 nodules) K4 is the HD DADO version for square and flat section structures

# FX30SA

Anti-torsion

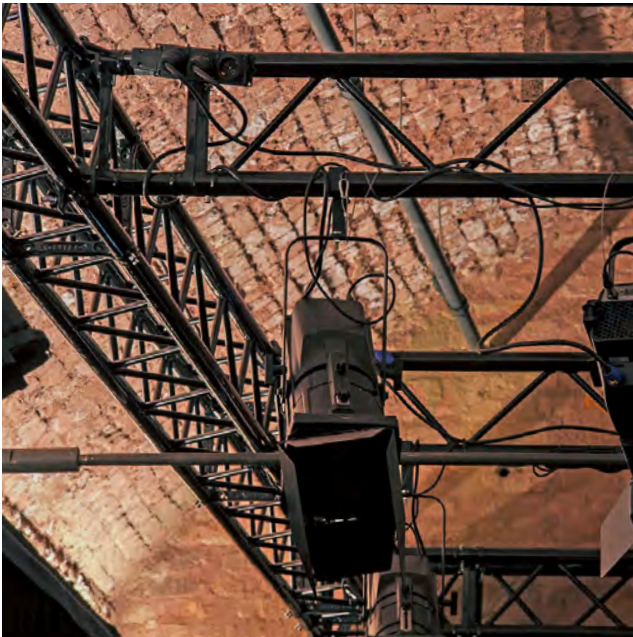

Flat section aluminium truss with 29 cm long sides. The most widely used of the flat, end-plated trusses. Ideal for use in reticular/grid structures and also perfectly suited for use alongside similar components supporting lightweight installations.

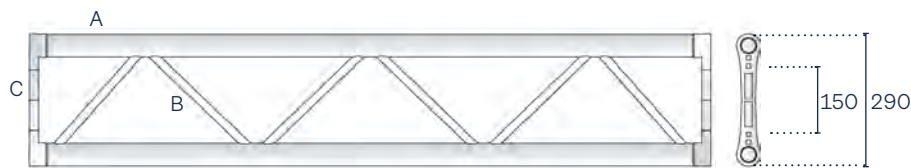

## Corners and fittings

code	cm	kg
FX30C2	29 x 5 x 5	1.3
FX30C4	29 x 29 x 5	3.3
FU30K2	29 x 5 x 5	1.4
FU30K4	29 x 29 x 5	3.7
FX30SAL2060P	50 x 50 x 5	3.8
FX30SAL2060V	50 x 50 x 29	3.0
FX30SAL2090P	50 x 50 x 5	2.5
FX30SAL2090V	50 x 50 x 29	2.8
FX30SAL2120P	50 x 50 x 5	2.6
FX30SAL2120V	50 x 50 x 29	2.9
FX30SAL2135P	50 x 50 x 5	2.7
FX30SAL2135V	50 x 50 x 29	2.9
FX30SAL3LP	50 x 50 x 50	3.8
FX30SAL3LV	50 x 50 x 50	3.8
FX30SAL3RP	50 x 50 x 50	3.8
FX30SAL3RV	50 x 50 x 50	3.7
FX30SAT3NP	50 x 50 x 5	2.9
FX30SAT3NV	50 x 50 x 29	4.2
FX30SAT4NP	50 x 50 x 50	3.0
FX30SAT4NV	50 x 50 x 50	4.2
FX30SAX4NP	50 x 50 x 5	3.4
FX30SAX4NV	50 x 50 x 29	3.9
FX30SAAACL	29 x 21 x 5	2.4
FX30SAAACS	29 x 10.5 x 5	2.1

## Chords A

Extruded tube  $\varnothing$  50 x 2 mm  
EN AW – 6082 T6

## Diagonals B

Extruded tube  $\varnothing$  18 x 2 mm  
EN AW – 6082 T6

## Ends C

Aluminium casting plate  
EN AC – 42200 KT6

## Connection systems

QXFC: quick-fit kit  
QXSM10: bolt connection kit

## Linear elements

code	cm	kg
FX30SA010M5	29 x 5 x 10.5	1.3
FX30SA021	29 x 5 x 21	1.5
FX30SA025	29 x 5 x 25	1.6
FX30SA050	29 x 5 x 50	1.8
FX30SA100	29 x 5 x 100	2.7
FX30SA150	29 x 5 x 150	3.7
FX30SA200	29 x 5 x 200	4.7
FX30SA250	29 x 5 x 250	5.8
FX30SA300	29 x 5 x 300	6.7
FX30SA350	29 x 5 x 350	7.7
FX30SA400	29 x 5 x 400	8.7



### Axial load table



Axial load	
H m	kg
2	251
3	111
4	63

Load table has been prepared in accordance with UNI ENV 1999-1-1 (Eurocode 9). When calculating the allowable loads it is assumed that the load is suspended from the bottom chord and the truss is supported from the top chord at each end.

The values shown in the table are the allowable static loads that can be applied to the truss. This is the live load or the payload.

The self weight of the truss has been taken into account when calculating the values in the table.

It should be noted that this are idealised loading conditions and the User shall re-analyze the truss for the loading conditions which prevail for the application being considered.

### Load table / Spigot connection



SPAN	Unif. distributed load			Centre point load			Third point load			Quarter point load			Fifth point load		
	Point load	Full load	Central deflection	Point load	Full load	Central deflection	Point load	Full load	Central deflection	Point load	Full load	Central deflection	Point load	Full load	Central deflection
m	kg/m	kg	mm	kg	kg	mm	kg	kg	mm	kg	kg	mm	kg	kg	mm
1	935	935	0	804	804	0	437	874	0	298	895	0	227	906	0
2	332	664	1	332	332	1	249	498	1	166	498	1	138	553	1
3	103	309	2	155	155	1	116	232	2	77	232	2	64	258	2
4	33	131	2	65	65	2	49	98	2	33	98	2	27	109	2
5	13	63	2	31	31	2	23	47	2	16	47	2	13	52	2
6	5	31	2	16	16	2	12	24	2	8	24	2	7	26	2

# FX30SA

## System

To further enhance the standard products, LITEC offers a wide range of corners, connections and accessories useful for many different applications and needs. "Quick connect" or "nult & bolt connect". End-plated trusses allow to use two different systems of connection. The quick-fit system is certainly the most wide-spread and mainly used when the structure is frequently assembled and dismantled. In case of permanent installations, on the other hand, a more economical bolt connection system may be used. Our plate is made in such a way that bolts may be completely inserted so that there are no edges or external protuberances which could damage canvases or other fabrics or which might simply be unaesthetic on certain structures.

## Connections



**KSG**  
Litecstruss aluminium spigot, set of 10



**KCP**  
R-spring, set of 100



**KSP**  
Steel pin, set of 10



**K370-4**  
Half truss spigot + 1 steel pin + 1 R-spring (not for Dado)



**KSFH**  
Threaded pin, set of 12



**KCFS**  
Kit for vert. connec incl. bolts, spigots and accessories



**FXFC**  
Quick connection set



**FXCFC**  
2 special steel half spigots with screws for Light Duty Dado



**FXSM10\***  
Bolt connection set for 30-40 series



**KSN**  
Threaded pin, set of 10



**FUKFC**  
2 special steel half spigots with screws for Heavy Duty Dado

**\* Achtung!**  
werden nur die Schraubverbinder eingesetzt, verringert sich die Tragkraft um 50%

## Accessories



**FX30SAACL**  
ST 29 cm. flat - Clamp module long



**FX30SAACS**  
ST 29 cm. flat - Clamp module short



**FP30**  
Universal 29 cm truss floor plate (30 x 30 cm)



**FP30M**  
Universal 29 cm truss large floor plate (50 x 50 cm)



**TZ30C01**  
Assembly tool for half-spigot in 25 & 29cm side trusses with Light Duty Dado



**TZ30K01**  
Assembly tool for half-spigot in 25 & 29 cm side trusses with Heavy Duty Dado



**CL2D50**  
Transport clip. Plastic casting for truss stacking. Fits 48 - 51 mm tube

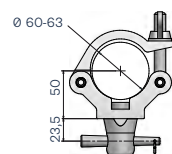

**LT C370**  
Truss clamp ALI6063 1/2 spigot swl 500kg



## Dados, Corners & fittings



**FX30SAL2060P**

ST 29 cm. flat - 2 way 60° corner horizontal



**FX30SAL2060V**

ST 29 cm. flat - 2 way 60° corner vertical



**FX30SAL2090P**

ST 29 cm. flat - 2 way 90° corner horizontal



**FX30SAL2090V**

ST 29 cm. flat - 2 way 90° corner vertical



**FX30SAL2120P**

ST 29 cm. flat - 2 way 120° corner horizontal



**FX30SAL2120V**

ST 29 cm. flat - 2 way 120° corner vertical



**FX30SAL2135P**

ST 29 cm. flat - 2 way 135° corner horizontal



**FX30SAL2135V**

ST 29 cm. flat - 2 way 135° corner vertical



**FX30SAL3LP**

ST 29 cm. flat - 3 way corner right horizontal



**FX30SAL3RP**

ST 29 cm. flat - 3 way corner right vertical



**FX30SAL3LV**

ST 29 cm. flat - 3 way tee horizontal



**FX30SAL3RV**

ST 29 cm. flat - 3 way tee vertical



**FX30SAT3NP**

ST 29 cm. flat - 4 way tee horizontal



**FX30SAT3NV**

ST 29 cm. flat - 4 way tee vertical



**FX30SAT4NP**

ST 29 cm. flat - 4 way cross horizontal



**FX30SAT4NV**

ST 29 cm. flat - 4 way cross vertical



**FX30SAX4NP**

ST 25 cm. flat - 4 way cross horizontal



**FX30SAX4NV**

ST 25 cm. flat - 4 way cross vertical

## Light duty Dado



**FX30C2**

DADO 4 way flat corner (2 nodules) C2 is the DADO version for flat section



**FX30C4**

DADO 6 way flat corner (4 nodules) C4 is the DADO version for square and flat section structures

## Heavy duty Dado



**FU30K2**

DADO 4 way flat corner (2 nodules) K2 is the HD DADO version for flat version



**FU30K4**

DADO 6 way flat corner (4 nodules) K4 is the HD DADO version for square and flat section structures

# TX25SA

Anti-torsion

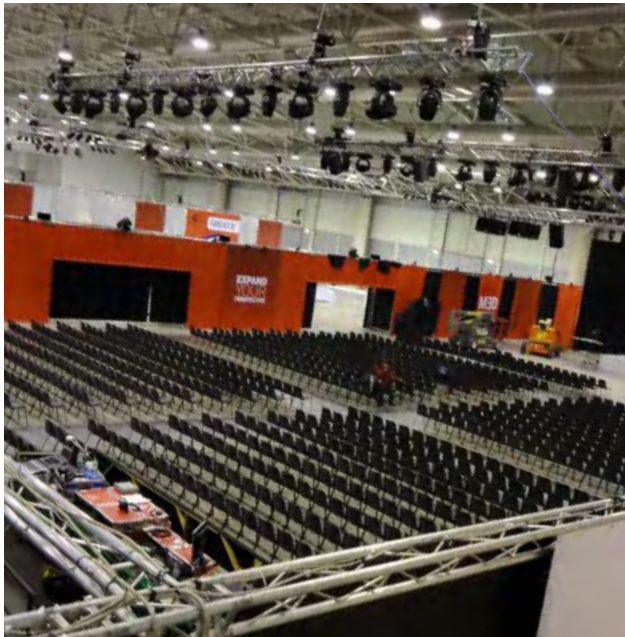

Triangular section aluminium truss with 25 cm long sides. This is the triangular version of the lightest professional structure, yet it is able to guarantee a reasonable loading capacity and span. The internal 14 mm diameter diagonal components are flush which decreases the aesthetic impact of this truss, which may therefore also be used in small areas.

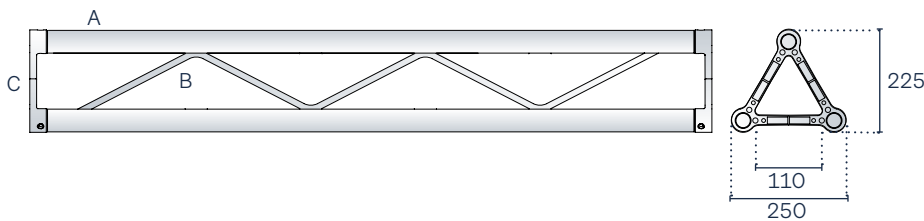

## Corners and fittings

code	cm	kg
TX25SAL2045	100 x 100 x 22.5	6.8
TX25SAL2060	100 x 100 x 22.5	7.2
TX25SAL2090	50 x 50 x 22.5	4.3
TX25SAL2090I	50 x 50 x 25	3.0
TX25SAL2090E	50 x 50 x 25	3.0
TX25SAL2120	50 x 50 x 22.5	3.0
TX25SAL2135	50 x 50 x 22.5	3.1
TX25SAL3L	50 x 50 x 50	4.2
TX25SAL3LU	50 x 50 x 50	4.1
TX25SAL3R	50 x 50 x 50	4.2
TX25SAL3RU	50 x 50 x 50	4.1
TX25SAT3	50 x 50 x 22.5	3.4
TX25SAT3F	50 x 25 x 50	3.6
TX25SAT3FU	50 x 25 x 50	3.5
TX25SAT4	50 x 50 x 50	4.8
TX25SAT4RU	50 x 50 x 50	4.9
TX25SAT4LU	50 x 50 x 50	4.9
TX25SAX4	50 x 50 x 22.5	4.0
TX25SAX5	50 x 50 x 50	6.1
TX25SAX5NU	50 x 50 x 50	6.1
TX25SAX6	50 x 50 x 50	6.1

## Chords A

Extruded tube  $\varnothing$  50.8 x 1.6 mm  
EN AW – 6060 T66

## Diagonals B

Extruded tube  $\varnothing$  14 x 1.5 mm  
EN AW – 6060 T6

## Ends C

Aluminium casting plate  
EN AC – 42200 KT6

## Connection systems

QXFC: quick-fit kit  
QXSM8: bolt connection kit

## Linear elements

code	cm	kg
TX25SA012M5	25 x 22.5 x 12.5	1.3
TX25SA025	25 x 22.5 x 25	1.6
TX25SA050	25 x 22.5 x 50	2.2
TX25SA100	25 x 22.5 x 100	3.6
TX25SA150	25 x 22.5 x 150	4.8
TX25SA200	25 x 22.5 x 200	5.8
TX25SA250	25 x 22.5 x 250	7.0
TX25SA300	25 x 22.5 x 300	8.1
TX25SA350	25 x 22.5 x 350	9.5
TX25SA400	25 x 22.5 x 400	10.6



### Load table / Spigot connection



SPAN	Unif. distributed load			Centre point load			Third point load			Quarter point load			Fifth point load		
	Point load	Full load	Central deflection	Point load	Full load	Central deflection	Point load	Full load	Central deflection	Point load	Full load	Central deflection	Point load	Full load	Central deflection
m	kg/m	kg	mm	kg	kg	mm	kg	kg	mm	kg	kg	mm	kg	kg	mm
1	433	433	0	433	433	0	217	433	0	144	433	0	108	433	0
2	214	429	1	429	429	2	214	429	2	143	429	2	107	429	1
3	142	425	4	411	411	6	212	425	6	142	425	5	106	425	5
4	105	421	10	314	314	12	210	421	13	140	421	12	105	421	12
5	83	417	19	253	253	19	183	366	23	128	383	22	104	417	23
6	69	412	33	209	209	27	153	306	34	104	313	32	87	348	34
7	50	530	46	175	175	38	130	261	47	88	263	44	73	292	46
8	37	299	60	149	149	50	112	224	62	75	224	58	62	249	61
9	29	258	77	129	129	63	97	193	78	64	193	73	54	215	77
10	22	224	95	112	112	79	84	168	97	56	168	91	47	187	95
11	18	196	115	98	98	97	73	147	117	49	147	111	41	163	116
12	14	172	138	86	86	117	64	129	140	43	129	132	36	143	138
13	12	151	162	75	75	139	56	113	165	38	113	156	31	125	163
14	9	132	189	66	66	164	49	99	192	33	99	183	27	110	190

### Cantilever load table / Spigot connection

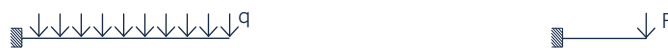

SPAN	Unif. distributed load			Centre point load		
	kg/m	kg	mm	kg	kg	mm
0.5	433	217	0	217	217	0
1.0	214	214	1	214	214	2
1.5	142	212	2	204	204	6
2.0	105	210	6	156	156	11
2.5	83	208	12	125	125	18
3.0	65	195	19	103	103	26

### Axial load table

SPAN	Axial load	
	kg	kg
m		
1.0	5675	5235
2.0	5420	3528
3.0	4986	1963
4.0	4323	1180
6.0	2770	
9.0	1407	

Load table has been prepared in accordance with UNI ENV 1999-1-1 (Eurocode 9). When calculating the allowable loads it is assumed that the load is suspended from the bottom chord and the truss is supported from the top chord at each end. The values shown in the table are the allowable static loads that can be applied to the truss. This is the live load or the payload.

The self weight of the truss has been taken into account when calculating the values in the table. It should be noted that this are idealised loading conditions and the User shall re-analyze the truss for the loading conditions which prevail for the application being considered.

# TX25SA

## System

To further enhance the standard products, LITEC offers a wide range of corners, connections and accessories useful for many different applications and needs. "Quick connect" or "nult & bolt connect". End-plated trusses allow to use two different systems of connection. The quick-fit system is certainly the most wide-spread and mainly used when the structure is frequently assembled and dismantled. In case of permanent installations, on the other hand, a more economical bolt connection system may be used. Our plate is made in such a way that bolts may be completely inserted so that there are no edges or external protuberances which could damage canvases or other fabrics or which might simply be unaesthetic on certain structures.

## Connections



**KSG**  
Litecstruss aluminium spigot, set of 10



**KCP**  
R-spring, set of 100

**KSP**  
Steel pin, set of 10



**K370-4**  
Half truss spigot + 1 steel pin + 1 R-spring (not for Dado)



**KSFH**  
Threaded pin, set of 12



**KCFs**  
Kit for vert. connec incl. bolts, spigots and accessories



**TXFC**  
Quick connection set



**TXSM8\***  
Bolt connection set for 25 series

**\* Achtung!**  
werden nur die Schraubverbinder eingesetzt, verringert sich die Tragkraft um 50%



**KSN**  
Threaded pin, set of 10

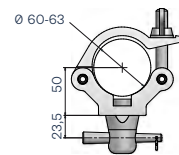

**LT C370**  
Truss clamp AL16063 1/2 spigot swl 500kg

## Accessories



**FP25**  
Universal 25 cm truss floor plate (25 x 25 cm)



**FP25M**  
Universal 25 cm truss floor plate (50 x 50 cm)



**C025WB**  
25 cm WALL BRACKET with Coupler



**CL2D50**  
Transport clip. Plastic casting for truss stacking. Fits 48 - 51 mm tube



**C025**  
BAR HOOK for 25 cm truss

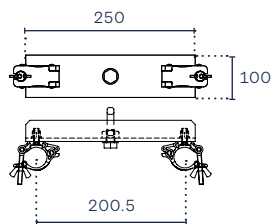

## Dados, Corners & fittings



**TX25SAL2045**

ST 25 cm. triangular  
2 way 45° corner



**TX25SAL2060**

ST 25 cm. triangular  
2 way 60° corner



**TX25SAL2090**

ST 25 cm. triangular  
2 way 90° corner



**TX25SAL2090E**

ST 25 cm. triangular  
2 ways 90° corner, ext. vertex



**TX25SAL2090I**

ST 25 cm. triangular 2 way 90°  
corner, int. vertex



**TX25SAL2120**

ST 25 cm. triangular  
2 way 120° corner



**TX25SAL2135**

ST 25 cm. triangular  
2 way 135° corner



**TX25SAL3L**

ST 25 cm. triangular  
3 way corner left



**TX25SAL3LU**

ST 25 cm. triangular  
3 way corner left vertex up



**TX25SAL3R**

ST 25 cm. triangular  
3 way corner right



**TX25SAL3RU**

ST 25 cm. triangular  
3 way corner left  
vertex up



**TX25SAT3**

ST 25 cm. triangular  
3 way tee



**TX25SAT3F**

ST 25 cm. triangular  
3 way tee foot  
vertex down



**TX25SAT3FU**

ST 25 cm. triangular  
3 way tee foot  
vertex up



**TX25SAT4**

ST 25 cm. triangular  
4 way tee



**TX25SAX4**

ST 25 cm. triangular  
4 way cross



**TX25SAX5**

ST 25 cm. triangular  
5 way cross vertex down



**TX25SAX6**

ST 25 cm. triangular  
6 way cross

# TX30SA

Anti-torsion

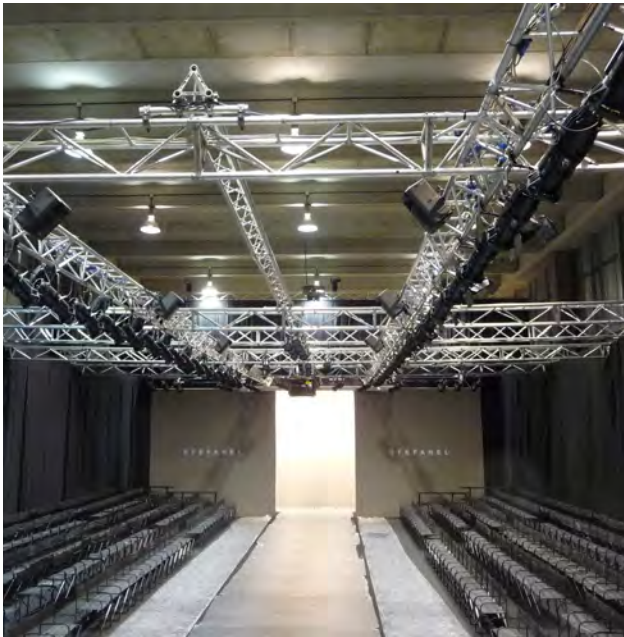

Triangular section aluminium truss with 29 cm long sides. This is the most popular version of all our triangular trusses. It is manufactured using 6082 aluminium alloy extruded components, with a high load-bearing capacity and twist-resistant strength. The diagonal chords have been re-configured and their diameter changed to improve the aesthetic appearance and increase the overall strength of the truss.

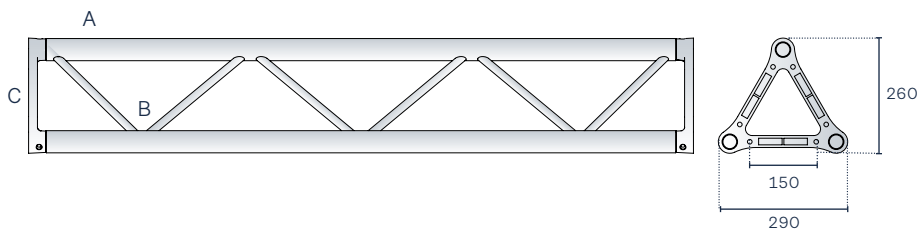

## Corners and fittings

code	cm	kg
TX30SAL2045	100 x 100 x 26	6.9
TX30SAL2045I	100 x 100 x 29	6.9
TX30SAL2060	100 x 100 x 26	7.0
TX30SAL2060I	100 x 100 x 29	7.1
TX30SAL2090	50 x 50 x 26	4.4
TX30SAL2090I	50 x 50 x 29	4.5
TX30SAL2120	50 x 50 x 26	4.6
TX30SAL2120I	50 x 50 x 29	4.9
TX30SAL2135	50 x 50 x 26	4.9
TX30SAL2135I	50 x 50 x 29	5.0
TX30SAL3L	50 x 50 x 50	6.5
TX30SAL3LU	50 x 50 x 50	6.3
TX30SAL3R	50 x 50 x 50	6.4
TX30SAL3RU	50 x 50 x 50	6.3
TX30SAT3	50 x 50 x 26	5.5
TX30SAT3F	29 x 50 x 50	5.8
TX30SAT3FU	29 x 50 x 50	5.5
TX30SAT4	50 x 50 x 50	7.5
TX30SAT4RU	50 x 50 x 50	7.8
TX30SAT4LU	50 x 50 x 50	7.8
TX30SAX4	50 x 50 x 26	6.2
TX30SAX5	50 x 50 x 50	8.4
TX30SAX5NU	50 x 50 x 50	8.6
TX30SAX6	50 x 50 x 50	9.3

## Chords A

Extruded tube  $\varnothing$  50 x 2 mm  
EN AW – 6082 T6

## Diagonals B

Extruded tube  $\varnothing$  18 x 2 mm  
EN AW – 6082 T6

## Ends C

Aluminium casting plate  
EN AC – 42200 KT6

## Connection systems

QXFC: quick-fit kit  
QXSM10: bolt connection kit

## Linear elements

code	cm	kg
TX30SA010M5	29 x 26 x 10.5	2.3
TX30SA021	29 x 26 x 21	2.6
TX30SA025	29 x 26 x 25	2.7
TX30SA050	29 x 26 x 50	3.7
TX30SA100	29 x 26 x 100	5.4
TX30SA150	29 x 26 x 150	7.2
TX30SA200	29 x 26 x 200	9.0
TX30SA250	29 x 26 x 250	10.7
TX30SA300	29 x 26 x 300	12.5
TX30SA350	29 x 26 x 350	14.2
TX30SA400	29 x 26 x 400	16.0



### Load table / Spigot connection



SPAN	Unif. distributed load			Centre point load			Third point load			Quarter point load			Fifth point load		
	Point load	Full load	Central deflection	Point load	Full load	Central deflection	Point load	Full load	Central deflection	Point load	Full load	Central deflection	Point load	Full load	Central deflection
m	kg/m	kg	mm	kg	kg	mm	kg	kg	mm	kg	kg	mm	kg	kg	mm
1	1819	1819	0	1461	1461	0	909	1819	1	606	1819	0	455	1819	0
2	781	1563	3	781	781	2	586	1172	3	391	1172	2	326	1302	3
3	345	1034	6	517	517	5	388	776	6	259	776	6	215	862	6
4	192	768	10	384	384	8	288	576	11	192	576	10	160	640	10
5	121	606	16	303	303	13	227	454	17	151	454	15	126	505	16
6	83	497	23	248	248	19	186	372	24	124	372	22	103	414	24
7	60	417	32	209	209	26	156	313	33	104	313	30	87	348	32
8	45	356	42	178	178	34	134	267	43	89	267	40	74	297	42
9	34	308	53	154	154	44	116	231	54	77	231	51	64	257	53
10	27	268	66	134	134	55	101	201	67	67	201	63	56	224	66
11	21	234	79	117	117	67	88	176	81	59	176	76	49	195	80
12	17	205	94	102	102	80	77	154	96	51	154	91	43	171	95
13	14	179	111	90	90	95	67	134	113	45	134	107	37	149	112
14	11	157	129	78	78	111	59	118	131	39	118	124	33	131	129
15	9	136	148	68	68	129	51	102	150	34	102	143	28	114	148
16	7	118	168	59	59	148	44	89	170	30	89	163	25	99	169

### Cantilever load table / Spigot connection



SPAN	Unif. distributed load			Centre point load		
	kg/m	kg	mm	kg	kg	mm
1	727	727	1	420	420	2
2	207	414	7	214	214	9
3	92	275	15	139	139	21
4	50	200	28	101	101	37
5	30	152	44	77	77	57
6	20	119	64	60	60	81

### Axial load table

SPAN	Axial load	
	kg	kg
1.0	6391	5841
2.0	6078	3920
3.0	5527	2299
4.0	4754	1429
6.0	3146	
9.0	1688	

Load table has been prepared in accordance with UNI ENV 1999-1-1 (Eurocode 9). When calculating the allowable loads it is assumed that the load is suspended from the bottom chord and the truss is supported from the top chord at each end. The values shown in the table are the allowable static loads that can be applied to the truss. This is the live load or the payload.

The self weight of the truss has been taken into account when calculating the values in the table. It should be noted that this are idealised loading conditions and the User shall re-analyze the truss for the loading conditions which prevail for the application being considered. The load tables values refer to the use of the truss with the apex down.

# TX30SA

## System

To further enhance the standard products, LITEC offers a wide range of corners, connections and accessories useful for many different applications and needs. "Quick connect" or "nult & bolt connect". End-plated trusses allow to use two different systems of connection. The quick-fit system is certainly the most wide-spread and mainly used when the structure is frequently assembled and dismantled. In case of permanent installations, on the other hand, a more economical bolt connection system may be used. Our plate is made in such a way that bolts may be completely inserted so that there are no edges or external protuberances which could damage canvases or other fabrics or which might simply be unaesthetic on certain structures.

## Connections



**KSG**  
Litecstruss aluminium spigot, set of 10



**KCP**  
R-spring, set of 100



**KSP**  
Steel pin, set of 10



**K370-4**  
Half truss spigot + 1 steel pin + 1 R-spring (not for Dado)



**KSFH**  
Threaded pin, set of 12

**KCFS**  
Kit for vert. connec. incl. bolts, spigots and accessories



**TXFC**  
Quick connection set



**TXSM8\***  
Bolt connection set for 25 series

**\* Achtung!**  
werden nur die Schraubverbinder eingesetzt, verringert sich die Tragkraft um 50%



**KSN**  
Threaded pin, set of 10

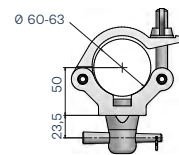

**LT C370**  
Truss clamp AL16063 1/2 spigot swl 500kg

## Accessories



**FP30**  
Universal 29 cm truss floor plate (30 x 30 cm)



**FP30M**  
Universal 29 cm truss large floor plate (50 x 50 cm)



**CO30WB**  
29 cm wall bracket W/half couplers



**CBT3040**  
2 points Bridle Hook for 29/40 cm. truss

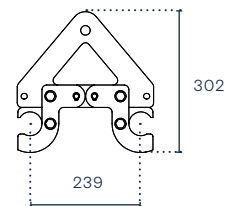

**CL2D50**  
Transport clip. Plastic casting for truss stacking. Fits 48 - 51 mm tube



**QU3040H050**  
30-40 Special Truss L=050 with hoist support



**CO30**  
Bar hook for 29 cm. truss

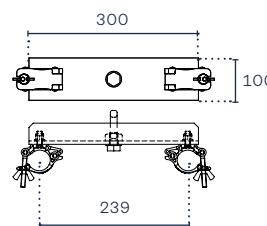



## Dados, Corners & fittings



**TX30SAL2045**

ST 30 cm. triangular  
2 way 45° corner



**TX30SAL2060**

ST 30 cm. triangular  
2 way 60° corner



**TX30SAL2090**

ST 30 cm. triangular  
2 way 90° corner



**TX30SAL2090E**

ST 30 cm. triangular  
2 ways 90° corner, ext. vertex



**TX30SAL2090I**

ST 30 cm. triangular 2 way 90°  
corner, int. vertex



**TX30SAL2120**

ST 30 cm. triangular  
2 way 120° corner



**TX30SAL2135**

ST 30 cm. triangular  
2 way 135° corner



**TX30SAL3L**

ST 30 cm. triangular  
3 way corner left



**TX30SAL3LU**

ST 30 cm. triangular  
3 way corner left vertex up



**TX30SAL3R**

ST 30 cm. triangular  
3 way corner right



**TX30SAL3RU**

ST 30 cm. triangular  
3 way corner left  
vertex up



**TX30SAT3**

ST 30 cm. triangular  
3 way tee



**TX30SAT3F**

ST 30 cm. triangular  
3 way tee foot  
vertex down



**TX30SAT3FU**

ST 30 cm. triangular  
3 way tee foot  
vertex up



**TX30SAT4**

ST 30 cm. triangular  
4 way tee



**TX30SAX4**

ST 30 cm. triangular  
4 way cross



**TX30SAX5**

ST 30 cm. triangular  
5 way cross vertex down



**TX30SAX6**

ST 30 cm. triangular  
6 way cross



**TU30BHH**

Truss Hinge 29 cm Triangular

# QX25SA

Anti-torsion



Square section aluminium truss with 25 cm long sides.

It is the lightest professional structure, yet it is able to guarantee a reasonable loading capacity and span. The internal 14 mm diameter diagonal components are flush which decreases the aesthetic impact of this truss, which may therefore also be used in small areas.

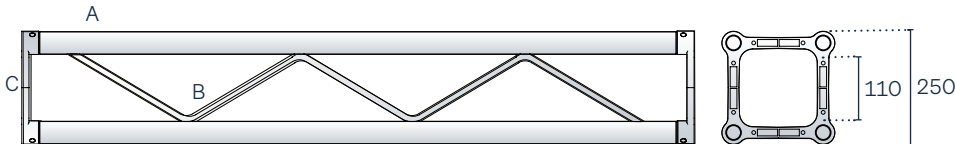

## Corners and fittings

code	cm	kg
FX25C4	25 x 25 x 5	3.3
QX25C8	25 x 25 x 25	7.0
FU25K4	25 x 25 x 5	3.4
QU25K8	25 x 25 x 25	8.4
QX25SAL2045	100 x 100 x 25	6.8
QX25SAL2060	100 x 100 x 25	7.2
QX25SAL2090	50 x 50 x 25	4.3
QX25SAL2120	50 x 50 x 25	4.4
QX25SAL2135	50 x 50 x 25	4.7
QX25SAL2ADJ	50 x 50 x 25	5.9
QX25SAL3	50 x 50 x 25	5.9
QX25SAT3	50 x 50 x 50	5.3
QX25SAT4	50 x 50 x 50	6.9
QX25SAX4	50 x 50 x 25	6.6
QX25SAX5	50 x 50 x 50	8.0
QX25SAX6	50 x 50 x 50	9.0
QX25SAACL	25 x 25 x 25	3.5
QX25SAACS	25 x 12.5 x 25	3.4
QX25SAACSC	25 x 12.5 x 25	3.4

## Chords A

Extruded tube  $\varnothing$  50.8 x 1.6 mm  
EN AW – 6060 T66

## Diagonals B

Extruded tube  $\varnothing$  14 x 1.5 mm  
EN AW – 6060 T6

## Ends C

Aluminium casting plate  
EN AC – 42200 KT6

## Connection systems

QXFC: quick-fit kit  
QXSM8: bolt connection kit

## Linear elements

code	cm	kg
QX25SA012M5	25 x 25 x 12.5	2.5
QX25SA025	25 x 25 x 25	2.8
QX25SA050	25 x 25 x 50	3.5
QX25SA100	25 x 25 x 100	5.2
QX25SA150	25 x 25 x 150	6.8
QX25SA200	25 x 25 x 200	8.4
QX25SA250	25 x 25 x 250	10.0
QX25SA300	25 x 25 x 300	11.6
QX25SA350	25 x 25 x 350	13.3
QX25SA400	25 x 25 x 400	14.9



### Load table / Spigot connection



SPAN	Unif. distributed load			Centre point load			Third point load			Quarter point load			Fifth point load		
	Point load	Full load	Central deflection	Point load	Full load	Central deflection	Point load	Full load	Central deflection	Point load	Full load	Central deflection	Point load	Full load	Central deflection
m	kg/m	kg	mm	kg	kg	mm	kg	kg	mm	kg	kg	mm	kg	kg	mm
1	501	501	0	501	501	0	251	501	0	167	501	0	125	501	0
2	248	497	1	497	497	1	248	497	1	166	497	1	124	497	1
3	164	492	2	492	492	4	246	492	3	164	492	3	123	492	3
4	122	488	6	488	488	9	244	488	8	163	488	7	122	488	7
5	97	483	11	483	483	18	242	483	15	161	483	14	121	403	14
6	80	478	20	466	466	30	239	478	26	159	478	25	120	478	23
7	68	474	37	404	404	42	237	474	42	158	474	39	118	474	37
8	59	469	47	354	354	55	235	469	62	156	469	58	117	469	56
9	52	465	66	315	315	71	226	453	86	155	465	82	116	465	79
10	46	460	91	282	282	89	204	407	108	142	425	105	115	460	108
11	41	456	121	253	253	109	185	369	133	127	380	127	106	422	134
12	38	451	158	228	228	131	168	336	160	114	342	152	95	380	160
13	32	412	187	206	206	155	154	307	190	103	309	179	86	343	188
14	27	374	218	187	187	181	104	280	222	93	280	208	78	311	219

### Cantilever load table / Spigot connection



SPAN	Unif. distributed load			Centre point load		
	kg/m	kg	mm	kg	kg	mm
0.5	501	251	0	251	251	0
1	248	248	0	248	248	1
1.5	164	246	1	246	246	4
2	122	244	3	244	244	9
2.5	97	242	7	242	242	18
3	80	239	12	231	231	29

### Axial load table

SPAN		
	kg	kg
1.0	7376	6973
2.0	7144	5380
3.0	6742	3432
4.0	6143	2193
6.0	4526	
10.0	2165	

Load table has been prepared in accordance with UNI ENV 1999-1-1 (Eurocode 9). When calculating the allowable loads it is assumed that the load is suspended from the bottom chord and the truss is supported from the top chord at each end. The values shown in the table are the allowable static loads that can be applied to the truss. This is the live load or the payload.

The self weight of the truss has been taken into account when calculating the values in the table. It should be noted that this are idealised loading conditions and the User shall re-analyze the truss for the loading conditions which prevail for the application being considered.

# QX25SA

## System

To further enhance the standard products, LITEC offers a wide range of corners, connections and accessories useful for many different applications and needs. "Quick connect" or "nult & bolt connect". End-plated trusses allow to use two different systems of connection. The quick-fit system is certainly the most wide-spread and mainly used when the structure is frequently assembled and dismantled. In case of permanent installations, on the other hand, a more economical bolt connection system may be used.

Our plate is made in such a way that bolts may be completely inserted so that there are no edges or external protuberances which could damage canvases or other fabrics or which might simply be unaesthetic on certain structures.

## Connections



**KSG**  
Litec truss aluminium spigot, set of 10



**KCP**  
R-spring, set of 100  
**KSP**  
Steel pin, set of 10



**K370-4**  
Half truss spigot + 1 steel pin + 1 R-spring (not for Dado)



**KSFH / KSN**  
Threaded pin, set of 12 / Threaded pin, set of 10



**KCFS**  
Kit for vert. connec incl. bolts, spigots and accessories



**QXFC**  
Quick connection set for Q Series



**QXSM8\***  
Bolt connection set for 25 series

**\* Achtung!**  
werden nur die Schraubverbinder eingesetzt, verringert sich die Tragkraft um 50%



**QXCFC**  
4 special steel half spigots with screws for Light Duty Dado



**QUKFC**  
4 special steel half spigots with screws for Heavy Duty Dado

## Accessories



**QX25SAACL**  
ST 25 cm square Clamp module long



**QX25SAACS**  
ST 25 cm square Clamp module short



**TZ30C01**  
Assembly tool half-spigot in 25&29cm side trusses with Light Duty Dado



**TZ30K01**  
Assembly tool for half-spigot in 25&29cm side trusses with Heavy Duty Dado



**CL2D50**  
Transport clip. Plastic casting for truss stacking. Fits 48 - 51 mm tube



**FP25**  
Universal 25 cm truss floor plate (25 x 25 cm)



**FP25M**  
Universal 25 cm truss floor plate (50 x 50 cm)



**C025WB**  
25 cm WALL BRACKET with Coupler



**C025**  
Bar hook for 25 cm truss

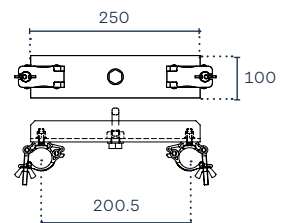

## Dados, Corners & fittings



**QX25SAL2045**  
ST 25 cm. square  
2 way 45° corner



**QX25SAL2060**  
ST 25 cm. square  
2 way 60° corner



**QX25SAL2090**  
ST 25 cm. square  
2 way 90° corner



**QX25SAL2120**  
ST 25 cm. square 2 ways  
120° corner, ext. vertex



**QX25SAL2135**  
ST 25 cm. square 2 way 135°  
corner, int. vertex



**QX25SAL3**  
ST 25 cm. square  
3 way corner



**QX25SAT3**  
ST 25 cm. square  
3 way tee



**QX25SAT4**  
ST 25 cm. square  
4 way tee



**QX25SAX4**  
ST 25 cm. square  
4 way cross



**QX25SAX5**  
ST 25 cm. square  
5 way cross



**QX25SAX6**  
ST 25 cm. square  
6 way cross

## Light duty Dado



**FX25C4**  
DADO 6 way flat corner (4  
nodules) C4 is the DADO  
version for square and flat  
section structures.



**QX25C8**  
DADO 6 way box corner (8  
nodules) C8 is the DADO version  
for square section structures



**FU25K4**  
DADO 6 way flat corner (4  
nodules) K4 is the HD DADO  
version for square and flat  
section structures



**QU25K8**  
Dado 6 way box corner (8  
nodules) K8 is the DADO version  
for square section structures

## Heavy duty Dado

# QX30SA

Anti-torsion



Square section aluminium truss twist-resistant version with 29 cm long sides. It substitutes the model QX30S, from which it keeps the excellent size, weight, cost and performance characteristics. It is made of 6082 alloy extruded components, with high load-bearing and twisting strength. It is a constitutive element of Unitower, Towerlift 3, and Flyintower 6-300 and Flyintower 7.5-500.

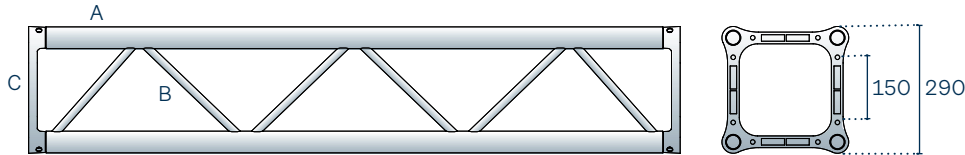

Chords A  
Extruded tube  $\varnothing$  50 x 2 mm  
EN AW – 6082 T6

Diagonals B  
Extruded tube  $\varnothing$  18 x 2 mm  
EN AW – 6082 T6

Ends C  
Aluminium casting plate  
EN AC – 42200 T6

Connection systems  
QXFC: quick-fit kit  
QXSM10: bolt connection kit

## Linear elements

code	cm	kg
QU30ADPO10M5	29 x 29 x 10.5	2.9
QU30ADPO19M5	29 x 29 x 19.5	3.6
QU30ADPO21	29 x 29 x 21	3.4
QX30SA025	29 x 29 x 25	3.6
QX30SA029	29 x 29 x 29	3.8
QX30SA050	29 x 29 x 50	4.8
QX30SA100	29 x 29 x 100	7.1
QX30SA150	29 x 29 x 150	9.5
QX30SA200	29 x 29 x 200	11.8
QX30SA250	29 x 29 x 250	14.1
QX30SA300	29 x 29 x 300	16.5
QX30SA350	29 x 40 x 350	18.8
QX30SA400	29 x 40 x 400	21.2

## Corners and fittings

code	cm	kg
FX30C4	29 x 29 x 5	3.3
QX30C8	29 x 29 x 29	9.0
FU30K4	29 x 29 x 5	3.7
QU30K8	29 x 29 x 29	9.5
QX30SAL2045	100 x 100 x 29	8.5
QX30SAL2060	100 x 100 x 29	9.2
QX30SAL2090	50 x 50 x 29	5.9
QX30SAL2120	50 x 50 x 29	6.9
QX30SAL2135	50 x 50 x 29	6.3
QX30SAL3	50 x 50 x 50	8.2
QX30SAT3	50 x 50 x 29	7.3
QX30SAT4	50 x 50 x 50	9.7
QX30SAX4	50 x 50 x 29	8.2
QX30SAX5	50 x 50 x 50	9.9
QX30SAX6	50 x 50 x 50	11.2
QX30SAACL	29 x 21 x 29	4.5
QX30SAACS	29 x 10.5 x 29	4.2
QX30SAACSC	29 x 12.4 x 29	5.2



### Load table / Spigot connection

SPAN	Unif. distributed load			Centre point load			Third point load			Quarter point load			Fifth point load		
	Point load	Full load	Central deflection	Point load	Full load	Central deflection	Point load	Full load	Central deflection	Point load	Full load	Central deflection	Point load	Full load	Central deflection
m	kg/m	kg	mm	kg	kg	mm	kg	kg	mm	kg	kg	mm	kg	kg	mm
1	2484	2484	0.3	2484	2484	0.4	1242	2484	0.4	828	2484	0.3	621	2484	0.3
2	1239	2478	2	1981	1981	3	1239	2478	3	826	2478	3	620	2478	3
3	824	2473	7	1386	1386	6	988	1976	8	720	2161	8	586	2344	8
4	550	2200	15	1057	1057	12	768	1536	14	542	1625	14	445	1779	15
5	350	1750	24	850	850	18	624	1248	23	433	1298	22	357	1427	23
6	241	1448	34	708	708	27	523	1046	33	359	1077	32	297	1187	34
7	176	1231	46	605	605	37	449	898	46	306	917	44	253	1013	46
8	133	1067	60	526	526	48	392	783	60	265	796	57	220	880	60
9	104	939	76	463	463	61	346	692	77	233	700	72	194	776	76
10	83	834	94	413	413	76	309	618	95	208	623	89	173	691	94
11	68	748	114	371	371	92	278	556	115	186	559	108	155	621	114
12	56	676	135	335	335	110	252	504	138	168	505	129	140	561	136
13	47	613	159	304	304	130	230	459	162	153	458	151	127	510	160
14	40	559	184	278	278	151	210	420	188	139	418	176	116	465	185
15	34	511	212	254	254	174	193	386	217	127	382	202	107	426	213
16	29	469	241	233	233	199	177	355	247	117	351	230	98	392	243
17	25	431	272	214	214	226	164	327	280	107	322	260	90	360	274
18	22	396	305	197	197	255	151	302	314	99	297	292	83	332	308

### Cantilever load table / Spigot connection

SPAN	Unif. distributed load			Centre point load	
	kg/m	kg	mm	kg	mm
1	1239	1239	1	990	3
2	491	982	8	528	12
3	227	681	19	354	26
4	128	512	35	262	47
5	81	405	55	206	73
6	55	330	79	167	105

### Axial load table

SPAN	kg
m	
3	6367
6	3215
9	1502
12	862

Load table has been prepared in accordance with UNI ENV 1999-1-1 (Eurocode 9). When calculating the allowable loads it is assumed that the load is suspended from the bottom chord and the truss is supported from the top chord at each end. The values shown in the table are the allowable static loads that can be applied to the truss. This is the live load or the payload.

The self weight of the truss has been taken into account when calculating the values in the table. It should be noted that this are idealised loading conditions and the User shall re-analyze the truss for the loading conditions which prevail for the application being considered.

# QX30SA

## System

To further enhance the standard products, LITEC offers a wide range of corners, connections and accessories useful for many different applications and needs. "Quick connect" or "nult & bolt connect". End-plated trusses allow to use two different systems of connection. The quick-fit system is certainly the most wide-spread and mainly used when the structure is frequently assembled and dismantled. In case of permanent installations, on the other hand, a more economical bolt connection system may be used.

Our plate is made in such a way that bolts may be completely inserted so that there are no edges or external protuberances which could damage canvases or other fabrics or which might simply be unaesthetic on certain structures.

## Connections



**KSG**  
Litec truss aluminium spigot, set of 10



**KCP**  
R-spring, set of 100



**K370-4**  
Half truss spigot + 1 steel pin + 1 R-spring (not for Dado)



**KSFH / KSN**  
Threaded pin, set of 12 / Threaded pin, set of 10



**KCFS**  
Kit for vert. connec. incl. bolts, spigots and accessories



**QXFC**  
Quick connection set for Q Series



**QXSM10\***  
Bolt connection set for 30 - 40 series

**\* Achtung!**  
werden nur die Schraubverbinder eingesetzt, verringert sich die Tragkraft um 50%



**QXCFC**  
4 special steel half spigots with screws for Light Duty Dado



**QUKFC**  
4 special steel half spigots with screws for Heavy Duty Dado

## Accessories



**QX30SAACS**  
ST 29 cm. square Clamp module short



**QX30SAACSC**  
ST 29 cm. square Clamp for Towerlift/Varitower



**QX30SAACL**  
29 cm square-clamp module-long



**CBT3040**  
2 points Bridle Hook for 29/40 cm. truss

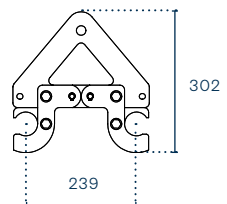

**FP30**  
Universal 29 cm truss floor plate (30 x 30 cm)



**FP30M**  
Universal 29 cm truss large floor plate (50 x 50 cm)



**CBQ3040**  
4 points Bridle Hook for 29/40 cm. truss



**C030**  
Bar hook for 29 cm. truss

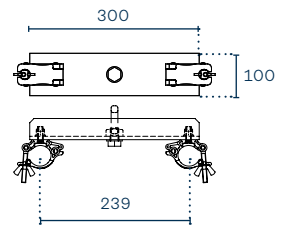





**TZ30K01**  
Assembly tool for half-spigot in 25&29cm side trusses with Heavy Duty Dado



**TZ30C01**  
Assembly tool for half-spigot in 25&29cm side trusses with Light Dado



**CS029-40**  
Ceiling support for 30-40 truss series – silver



**QU30TR**  
Lighting support



**QU30TRC**  
Lighting support - diameter 100 cm



**QU3040H050**  
30-40 Special Truss L=050 with hoist support



**XT-290-PC**  
Clip for cladding trusses with felt or other lightweight materials



**CO30WB**  
29 cm wall bracket W/half couplers



**CL2D50**  
Transport clip. Plastic casting for truss stacking. Fits 48 - 51 mm tube

## Dados, Corners & fittings



**QX30SAL2045**  
ST 29 cm. square 2 way 45° corner



**QX30SAL2060**  
ST 29 cm. square 2 way 60° corner



**QX30SAL2090**  
ST 29 cm. square 2 way 90° corner



**QX30SAL2120**  
ST 29 cm. square 2 ways 120° corner, ext. vertex



**QX30SAL2135**  
ST 29 cm. square 2 way 135° corner, int. vertex

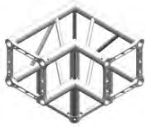

**QX30SAL3**  
ST 29 cm. square 3 way corner



**QX30SAT3**  
ST 29 cm. square 3 way tee



**QX30SAT4**  
ST 29 cm. square 4 way tee



**QX30SAX4**  
ST 29 cm. square 4 way cross



**QX30SAX5**  
ST 29 cm. square 5 way cross



**QX30SAX6**  
ST 29 cm. square 6 way cross



**QX30SAX8**  
ST 29 cm. square 8 way horizontal cross



**Q30SL2ADJ**  
Adjustable 2 way corner



**QU30BHH**  
Truss Hinge 29 cm square

## Light duty Dado



**FX30C4**  
DADO 6 way flat corner (4 nodules) C4 is the DADO version for square and flat section structures



**QX30C8**  
DADO 6 way box corner (8 nodules) C8 is the DADO version for square section structures



**QU30C8-ADP001**  
Adapter for Dado QU30K8



**FU30K4**  
DADO 6 way flat corner (4 nodules) K4 is the HD DADO version for square and flat section structures



**QU30K8**  
Dado 6 way box corner (8 nodules) K8 is the DADO version for square section structures



**QU30K8-ADP001**  
Adapter for Dado QU30K8

## Heavy duty Dado

# QX40SA

Anti-torsion



Square section aluminium truss twist-resistant version with 29 cm long sides. It substitutes the model QX40S, from which it keeps the excellent size, weight, cost and performance characteristics. It is made of 6082 alloy extruded components, with high load-bearing and twisting strength. It is a constitutive element of Unitower, Towerlift 3, and Flyintower 6-300 and Flyintower 7.5-500.

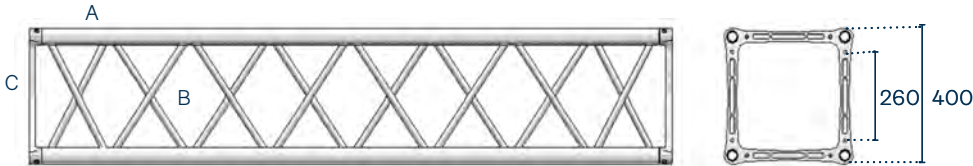

Chords A  
extruded tube  $\varnothing$  50 x 2 mm  
EN AW-6082 T6

Diagonals B  
extruded tube  $\varnothing$  20 x 2 mm  
EN AW-6082 T6

Ends C  
aluminium casting plate  
EN AC-42200 T6

Connection systems  
QXFC: quick-fit kit  
QXSM10: bolt connection kit

#### Linear elements

code	cm	kg
QU40ADPO10	40 x 40 x 10	4.4
QX40SA025	40 x 40 x 25	5.0
QX40SA050	40 x 40 x 50	6.7
QX40SA100	40 x 40 x 100	10.0
QX40SA150	40 x 40 x 150	13.2
QX40SA200	40 x 40 x 200	16.6
QX40SA250	40 x 40 x 250	19.9
QX40SA300	40 x 40 x 300	23.2
QX40SA350	40 x 40 x 350	26.5
QX40SA400	40 x 40 x 400	29.8

#### Corners and fittings

code	cm	kg
FX40C4	40 x 40 x 5	4.3
QX40C8	40 x 40 x 40	12.3
FU40K4	40 x 40 x 5	4.7
QU40K8	40 x 40 x 40	12.6
QX40SAL2ADJ	50 x 10 x 40	9.0
QX40SAL2045	150 x 150 x 40	10.9
QX40SAL2060	100 x 100 x 40	11.2
QX40SAL2090	50 x 50 x 40	7.6
QX40SAL2120	50 x 50 x 40	7.7
QX40SAL2135	50 x 50 x 40	7.9
QX40SAL3	50 x 50 x 50	9.8
QX40SAT3	100 x 50 x 40	12.0
QX40SAT4	50 x 100 x 50	14.3
QX40SAX4	100 x 100 x 40	16.0
QX40SAX5	100 x 100 x 50	18.5
QX40SAX6	100 x 100 x 100	22.0
QX40SAACS	29 x 10.5 x 29	4.2
QX40SAACSC	29 x 12.4 x 29	5.2



### Load table / Spigot connection

SPAN	Unif. distributed load			Centre point load			Third point load			Quarter point load			Fifth point load		
	Point load	Full load	Central deflection	Point load	Full load	Central deflection	Point load	Full load	Central deflection	Point load	Full load	Central deflection	Point load	Full load	Central deflection
m	kg/m	kg	mm	kg	kg	mm	kg	kg	mm	kg	kg	mm	kg	kg	mm
1	3065	3065	0	2865	2865	0	1532	3065	0	1022	3065	0	766	3065	0
2	1529	3058	1	2054	2054	1	1268	2537	1	953	2859	1	765	3058	1
3	1017	3052	4	1578	1578	3	1024	2047	4	797	2392	4	663	2651	4
4	761	3043	10	1273	1273	7	852	1703	8	680	2041	8	551	2205	9
5	494	2472	16	1063	1063	11	726	1452	13	584	1753	14	457	1827	14
6	346	2076	23	909	909	16	630	1260	19	492	1476	21	389	1554	21
7	255	1784	31	792	792	23	555	1110	27	424	1271	28	337	1349	2
8	195	1560	41	699	699	30	495	989	36	371	1113	37	297	1188	38
9	154	1383	53	624	624	39	445	890	46	329	987	48	265	1059	49
10	123	1235	65	562	562	48	403	806	58	295	884	59	238	952	61
11	101	1110	79	510	510	59	368	735	71	266	798	72	216	862	74
12	84	1005	94	465	465	71	337	674	86	242	726	86	196	786	89
13	70	916	110	426	426	84	310	620	102	221	663	101	180	720	105
14	60	838	127	392	392	98	286	572	119	203	608	118	165	662	122
15	51	770	146	362	362	114	265	530	138	187	560	136	153	610	14
16	44	709	166	335	335	131	246	492	159	172	517	155	141	564	161
17	39	655	188	310	310	149	229	458	180	159	478	176	131	523	182
18	34	606	211	288	288	168	213	427	203	148	443	197	121	486	205

### Cantilever load table / Spigot connection

SPAN	Unif. distributed load			Centre point load	
	kg/m	kg	mm	kg	mm
1	1427	1427	1	1024	1
2	508	1016	4	634	7
3	258	773	10	451	16
4	154	616	20	347	29
5	101	506	32	278	46
6	71	424	48	230	67

### Axial load table

SPAN	kg
m	
3	6949
6	5330
9	3069
12	1791

Load table has been prepared in accordance with UNI ENV 1999-1-1 (Eurocode 9). When calculating the allowable loads it is assumed that the load is suspended from the bottom chord and the truss is supported from the top chord at each end. The values shown in the table are the allowable static loads that can be applied to the truss. This is the live load or the payload.

The self weight of the truss has been taken into account when calculating the values in the table. It should be noted that this are idealised loading conditions and the User shall re-analyze the truss for the loading conditions which prevail for the application being considered.

To further enhance the standard products, LITEC offers a wide range of corners, connections and accessories useful for many different applications and needs. "Quick connect" or "nult & bolt connect". End-plated trusses allow to use two different systems of connection. The quick-fit system is certainly the most wide-spread and mainly used when the structure is frequently assembled and dismantled. In case of permanent installations, on the other hand, a more economical bolt connection system may be used.

Our plate is made in such a way that bolts may be completely inserted so that there are no edges or external protuberances which could damage canvases or other fabrics or which might simply be unaesthetic on certain structures.

## Connections



**KSG**  
Litetruss aluminium spigot, set of 10



**KCP**  
R-spring, set of 100



**KSP**  
Steel pin, set of 10



**K370-4**  
Half truss spigot + 1 steel pin + 1 R-spring (not for Dado)



**KSFH / KSN**  
Threaded pin, set of 12  
Threaded pin, set of 10



**KCFS**  
Kit for vert. connection incl. bolts, spigots and accessories



**QXFC**  
Quick connection set for Q Series



**QXSM10\***  
Bolt connection set for 30 - 40 series

**\* Achtung!**  
werden nur die Schraubverbinder eingesetzt, verringert sich die Tragkraft um 50%



**QXCFC**  
4 special steel half spigots with screws for Light Duty Dado



**QUKFC**  
4 special steel half spigots with screws for Heavy Duty Dado

## Accessories



**QX40SAACSC**  
ST 40 cm. square Clamp module Towerlift/Varitower



**C040**  
Bar hook for 40 cm. truss



**FP40**  
Universal 40 cm. truss floor plate (40x40 cm)



**FP30M**  
Universal truss large floor plate (50x50 cm)



**QU3040H050**  
30-40 Special Truss L=050 with hoist support



**TZ40K01**  
Assembly tool for half-spigot in 40 cm side trusses with Heavy Duty Dado



**TZ40C01**  
Assembly tool for half-spigot in 40 cm side trusses with Light Duty Dado



**CBQ3040**  
4 points Bridle Hook for 29/40 cm. truss



**CBT3040**  
2 points Bridle Hook for 29/40 cm. truss

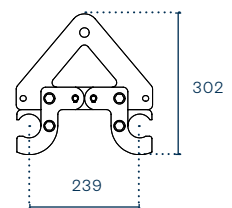



**CS029-40**  
Ceiling support for 30-40 truss series – silver



**CL2D50**  
Transport clip. Plastic casting for truss stacking. Fits 48 - 51 mm tube

## Dados, Corners & fittings



**QX40SAL2045**  
ST 40 cm. square  
2 way 45° corner



**QX40SAL2060**  
ST 40 cm. square  
2 way 60° corner

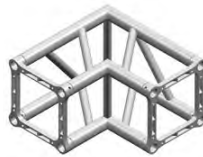

**QX40SAL2090**  
ST 40 cm. square  
2 way 90° corner



**QX40SAL2120**  
ST 40 cm. square 2 ways  
120° corner, ext. vertex



**QX40SAL2135**  
ST 40 cm. square 2 way 135°  
corner, int. vertex



**QX40SAL3**  
ST 40 cm. square  
3 way corner



**QX40SAT3**  
ST 40 cm. square  
3 way tee



**QX40SAT4**  
ST 40 cm. square  
4 way tee



**QX40SAX4**  
ST 40 cm. square  
4 way cross



**QX40SAX5**  
ST 40 cm. square  
5 way cross



**QX40SAX6**  
ST 40 cm. square  
6 way cross



**Q40SL2ADJ**  
Adjustable 2 way corner

## Light duty Dado



**FX40C4**  
DADO 6 way flat corner (4 nodules)  
C4 is the DADO version for square and flat section structures



**QX40C8**  
DADO 6 way box corner (8 nodules)  
C8 is the DADO version for square and flat section structures



**FU40K4**  
DADO 6 way flat corner (4 nodules).  
K4 is the HD DADO version for square and flat section structures.



**QU40K8**  
Dado 6 way box corner (8 nodules).  
K8 is the HD DADO version for square and flat section structures.

## Heavy duty Dado

# TH30SA

Anti-torsion



The TH30SA triangular truss from LITEC includes this unique end-plate design, thereby making it the right choice for your Light and Medium-duty applications and providing extreme durability for rental applications. The 48 x 3 mm main chords also make it compatible with the most popular scaffolding clamping systems. Constructed from extruded 6082 aluminium alloy, it features high load bearing capacity and twist-resistant strength.

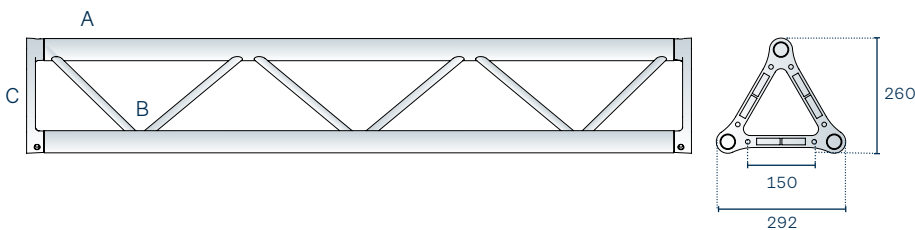

Chords A  
Extruded tube  $\varnothing$  48 x 3 mm  
EN AW – 6082 T6

Diagonals B  
Extruded tube  $\varnothing$  20 x 2 mm  
EN AW – 6082 T6

End C  
Aluminium casting plate  
EN AC – 42200 KT6

Connection systems  
QXFC: quick-fit kit  
QXSM10: bolt connection kit

#### Linear elements

code	cm	kg
TH30SA010M5	29 x 26 x 10.5	2.3
TH30SA021	29 x 26 x 21	2.6
TH30SA025	29 x 26 x 25	2.7
TH30SA050	29 x 26 x 50	3.7
TH30SA100	29 x 26 x 100	5.4
TH30SA150	29 x 26 x 150	7.2
TH30SA200	29 x 26 x 200	9.0
TH30SA250	29 x 26 x 250	10.7
TH30SA300	29 x 26 x 300	12.5
TH30SA350	29 x 26 x 350	14.2
TH30SA400	29 x 26 x 400	16.0

#### Corners and fittings

code	cm	kg
TH30SAL2045	100 x 100 x 26	6.9
TH30SAL2060	100 x 100 x 26	7.0
TH30SAL2090	50 x 50 x 26	4.4
TH30SAL2090E	50 x 50 x 29	4.5
TH30SAL2120	50 x 50 x 26	4.6
TH30SAL3L	50 x 50 x 50	6.5
TH30SA3LU	50 x 50 x 50	6.5
TH30SAL3RU	50 x 50 x 50	6.3
TH30SAT3	50 x 50 x 26	5.5
TH30SAT3F	29 x 50 x 50	5.8
TH30SAT3FU	29 x 50 x 50	5.5
TH30SAT4	50 x 50 x 50	7.5
TH30SAT4FU	50 x 50 x 50	7.8
TH30SAT4LU	50 x 50 x 50	7.8
TH30SAX4	50 x 50 x 26	6.2
TH30SAX5	50 x 50 x 50	8.4
TH30SA5NU	50 x 50 x 50	8.6
TH30SAX6	50 x 50 x 50	9.3



### Load table / Spigot connection

SPAN	Unif. distributed load			Centre point load			Third point load			Quarter point load			Fifth point load		
	Point load	Full load	Central deflection	Point load	Full load	Central deflection	Point load	Full load	Central deflection	Point load	Full load	Central deflection	Point load	Full load	Central deflection
m	kg/m	kg	mm	kg	kg	mm	kg	kg	mm	kg	kg	mm	kg	kg	mm
2	1070	2141	3	1093	1093	2	820	1639	3	547	1640	2	455	1822	3
3	483	1450	6	725	725	5	544	1087	6	362	1087	6	302	1208	6
4	270	1079	10	540	540	8	405	809	11	270	809	10	225	899	10
5	171	855	16	427	427	13	321	641	17	214	641	15	178	712	16
6	117	704	23	352	352	19	264	528	24	176	528	22	147	586	24
7	85	595	32	297	297	26	223	446	32	149	446	30	124	496	32
8	64	511	42	256	256	34	192	384	42	128	384	40	107	426	42
9	50	446	53	223	223	43	167	334	54	111	334	50	93	372	53
10	39	392	65	196	196	54	147	294	67	98	294	62	82	327	66
11	32	348	79	174	174	66	130	261	81	87	261	76	72	290	80
12	26	310	94	155	155	79	116	232	96	77	232	90	65	258	95
13	21	277	111	139	139	93	104	208	113	69	208	107	58	231	112
14	18	248	129	124	124	109	93	186	131	62	186	124	52	207	130
15	15	222	149	111	111	127	83	167	151	56	167	143	46	186	150
16	13	200	170	100	100	146	75	150	173	50	150	164	39	166	171

Load table has been prepared in accordance with din4113 and DIN18800. When calculating the allowable loads it is assumed that the load is suspended from the bottom chord and the truss is supported from the top chord at each end. The values shown in the table are the allowable static loads that can be applied to the truss. This is the live load or the payload. The self-weight of the truss has been taken into account when calculating the values in the table. It should

be noted that this are idealized loading conditions and the User shall re-analyze the truss for the loading conditions which prevail for the application being considered.

To further enhance the standard products, LITEC offers a wide range of corners, connections and accessories useful for many different applications and needs. "Quick connect" or "bolt & nut connect". End-plated trusses allow to use two different systems of connection. The quick-fit system is certainly the most wide-spread and mainly used when the structure is frequently assembled and dismantled. In case of permanent installations, on the other hand, a more economical bolt connection system may be used. Our plate is made in such a way that bolts may be completely inserted so that there are no edges or external protuberances which could damage canvases or other fabrics or which might simply be unaesthetic on certain structures.

## Connections



**KSG**  
Litec truss aluminium spigot, set of 10



**KCP**  
R-spring, set of 100

**KSP**  
Steel pin, set of 10



**K370-4**  
Half truss spigot + 1 steel pin + 1 R-spring (not for Dado)



**KSFH / KSN**  
Threaded pin, set of 12/  
Threaded pin, set of 10



**KCFS**  
Kit for vert. connection incl. bolts, spigots and accessories



**QXFC**  
Quick connection set



**QXSM10\***  
Bolt connection set for 30-40 series

**\* Achtung!**  
werden nur die Schraubverbinder eingesetzt, verringert sich die Tragkraft um 50%

## Accessories



**FP30**  
Universal 29 cm truss floor plate (30 x 30 cm)



**FP30M**  
Universal 29 cm truss large floor plate (50x50 cm)



**CO30WB**  
29 cm wall bracket W/half couplers



**CBT3040**  
2 points Bridle Hook for 29/40 cm truss

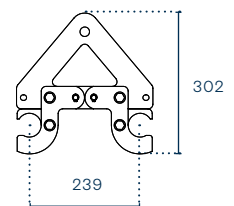

**CL2D50**  
Transport clip. Plastic casting for truss stacking. Fits 48 - 51 mm tube



**QU3040H050**  
30-40 Special Truss L=050 with hoist support



**C030**  
Bar hook for 29 cm truss

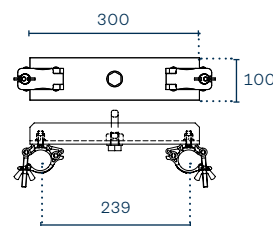



## Corners & fittings



**TH30SAL2045**  
ST 29 cm triangular  
2 way 45° corner



**TH30SAL2060**  
ST 29 cm triangular  
2 way 60° corner



**TH30SAL2090**  
ST 29 cm triangular  
2 way 90° corner



**TH30SAL2090E**  
ST 29 cm triangular  
2 ways 90° corner, ext. vertex



**TH30SAL2090I**  
ST 29 cm triangular 2 way 90°  
corner, int. vertex



**TH30SAL2120**  
ST 29 cm triangular  
2 way 120° corner



**TH30SAL2135**  
ST 29 cm triangular  
2 way 135° corner



**TH30SAL3L**  
ST 29 cm triangular  
3 way corner left



**TH30SAL3R**  
ST 29 cm triangular  
3 way corner right



**TH30SAT3**  
ST 29 cm triangular  
3 way tee



**TH30SAT4**  
ST 29 cm triangular  
4 way tee



**TH30SAX4**  
ST 29 cm triangular  
4 way cross



**TH30SAX5**  
ST 29 cm triangular  
5 way cross



**TH30SAX6**  
ST 29 cm triangular  
6 way cross



**TU30BHH**  
Truss Hinge 29 cm Triangular

# QH30SA

Anti-torsion

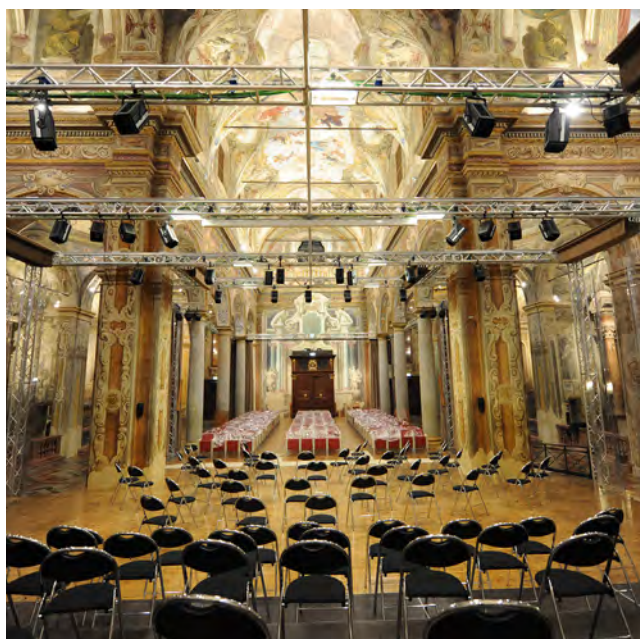

Square section heavy duty aluminium truss twist-resistant version with 29 cm long sides.

It substitutes the old Heavy Duty series QD30S and QD30SA.

It is characterized by the introduction of  $\varnothing 48 \times 3$  mm chords and  $\varnothing 20 \times 2$  mm diagonals on all the faces. This truss constitutes Varitower 3-30 and Flyintower 9.5-600.

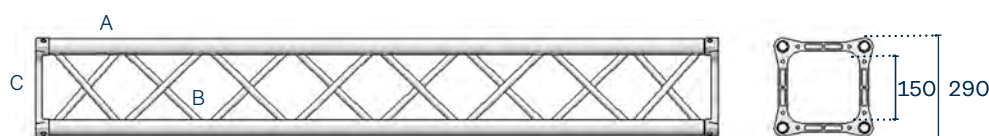

Chords A  
extruded tube  $\varnothing 48 \times 3$  mm  
EN AW-6082 T6

Diagonals B  
extruded tube  $\varnothing 20 \times 2$  mm  
EN AW-6082 T6

Ends C  
aluminium casting plate  
EN AC-42200 T6

Connection systems  
QXFC: quick-fit kit  
QXSM10: bolt connection kit

#### Linear elements

code	cm	kg
QU30ADPO10M5	29 x 29 x 10.5	2.9
QU30ADPO19M5	29 x 29 x 19.5	3.6
QU30ADPO21	29 x 29 x 21	3.4
QH30SA025	29 x 29 x 25	3.6
QH30SA029	29 x 29 x 29	3.8
QH30SA050	29 x 29 x 50	4.8
QH30SA100	29 x 29 x 100	7.1
QH30SA150	29 x 29 x 150	9.5
QH30SA200	29 x 29 x 200	11.8
QH30SA250	29 x 29 x 250	14.1
QH30SA300	29 x 29 x 300	16.5
QH30SA350	29 x 40 x 350	18.8
QH30SA400	29 x 40 x 400	21.2

#### Corners and fittings

code	cm	kg
FX30C4	29 x 29 x 5	3.3
QX30C8	29 x 29 x 29	9.0
FU30K4	29 x 29 x 5	3.7
QU30K8	29 x 29 x 29	9.5
QH30SAL2045	100 x 100 x 29	8.5
QH30SAL2060	100 x 100 x 29	9.2
QH30SAL2090	50 x 50 x 29	5.9
QH30SAL2120	50 x 50 x 29	6.9
QH30SAL2135	50 x 50 x 29	6.3
QH30SAL3	50 x 50 x 50	8.2
QH30SAT3	50 x 50 x 29	7.3
QH30SAT4	50 x 50 x 50	9.7
QH30SAX4	50 x 50 x 29	8.2
QH30SAX5	50 x 50 x 50	9.9
QH30SAX6	50 x 50 x 50	11.2
QH30SAAACL	29 x 21 x 29	4.5
QH30SAAACS	29 x 10.5 x 29	4.2
QH30SAAACSC	29 x 12.4 x 29	5.2



### Load table / Spigot connection

SPAN	Unif. distributed load			Centre point load			Third point load			Quarter point load			Fifth point load		
	Point load	Full load	Central deflection	Point load	Full load	Central deflection	Point load	Full load	Central deflection	Point load	Full load	Central deflection	Point load	Full load	Central deflection
m	kg/m	kg	mm	kg	kg	mm	kg	kg	mm	kg	kg	mm	kg	kg	mm
1	2775	2775	0	2775	2775	0	1387	2775	0	925	2775	0	694	2775	0
2	1384	2768	2	2677	2677	3	1384	2768	2	923	2768	2	692	2768	2
3	920	2760	6	1894	1894	6	1335	2670	7	920	2760	7	690	2760	7
4	688	2753	13	1454	1454	11	1046	2092	14	753	2259	14	614	2454	14
5	492	2462	24	1175	1175	18	855	1709	22	603	1809	22	494	1976	23
6	340	2039	34	982	982	26	720	1439	33	501	1503	32	412	1649	33
7	248	1734	46	840	840	36	619	1239	45	427	1282	43	352	1410	45
8	188	1503	60	732	732	47	542	1083	59	371	1114	57	307	1227	60
9	147	1323	76	646	646	60	480	960	76	327	981	72	271	1083	76
10	118	1176	94	576	576	75	429	859	94	291	874	89	241	966	94
11	96	1056	114	518	518	91	387	774	114	262	785	108	217	869	114
12	79	954	136	469	469	109	351	703	136	237	710	129	197	786	135
13	67	866	159	427	427	129	320	641	161	215	645	151	179	715	159
14	56	790	185	390	390	150	294	587	187	196	589	176	163	654	185
15	48	723	212	357	357	173	270	540	215	180	539	202	150	600	213
16	42	664	241	328	328	198	249	497	246	165	495	230	138	551	242
17	36	611	272	302	302	225	230	459	278	152	456	260	127	508	274
18	31	563	305	278	278	254	213	425	313	140	420	292	117	469	307

### Cantilever load table / Spigot connection

SPAN	Unif. distributed load			Centre point load	
	kg/m	kg	mm	kg	mm
1	1384	1384	1	1337	3
2	663	1327	8	726	11
3	310	930	19	490	26
4	176	704	34	365	46
5	112	559	54	287	73
6	76	457	78	234	104

### Axial load table

SPAN	kg
m	
3	8873
6	4521
9	2112
12	1212

Load table has been prepared in accordance with UNI ENV 1999-1-1 (Eurocode 9). When calculating the allowable loads it is assumed that the load is suspended from the bottom chord and the truss is supported from the top chord at each end. The values shown in the table are the allowable static loads that can be applied to the truss. This is the live load or the payload.







The self weight of the truss has been taken into account when calculating the values in the table. It should be noted that this are idealised loading conditions and the User shall re-analyze the truss for the loading conditions which prevail for the application being considered.

To further enhance the standard products, LITEC offers a wide range of corners, connections and accessories useful for many different applications and needs. "Quick connect" or "nult & bolt connect". End-plated trusses allow to use two different systems of connection. The quick-fit system is certainly the most wide-spread and mainly used when the structure is frequently assembled and dismantled. In case of permanent installations, on the other hand, a more economical bolt connection system may be used. Our plate is made in such a way that bolts may be completely inserted so that there are no edges or external protuberances which could damage canvases or other fabrics or which might simply be unaesthetic on certain structures.

## Connections

 <p><b>KSG</b> Litetruss aluminium spigot, set of 10</p>	 <p><b>KCP</b> R-spring, set of 100</p>	 <p><b>KSP</b> Steel pin, set of 10</p>	 <p><b>K370-4</b> Half truss spigot + 1 steel pin + 1 R-spring (not for Dado)</p>	 <p><b>KSFH / KSN</b> Threaded pin, set of 12 / Threaded pin, set of 10</p>	 <p><b>KCFS</b> Kit for vert. connec. incl. bolts, spigots and accessories</p>
 <p><b>QXFC</b> Quick connection set for Q Series</p>	 <p><b>QXSM10*</b> Bolt connection set for 30 - 40 series</p>	<p><b>* Achtung!</b> werden nur die Schraubverbinder eingesetzt, verringert sich die Tragkraft um 50%</p>	 <p><b>QXCFC</b> 4 special steel half spigots with screws for Light Duty Dado</p>	 <p><b>QKQFC</b> 4 special steel half spigots with screws for Heavy Duty Dado</p>	

## Accessories

 <p><b>QH30SAACS</b> ST 29 cm. square Clamp module short</p>	 <p><b>QH30SAACL</b> ST 29 cm. square Clamp for Towerlift/Varitower</p>	 <p><b>QU30ADP010M5</b> Universal Adapter 29 cm square - Length 10.5 cm</p>	 <p><b>CBT3040</b> 2 points Bridle Hook for 29/40 cm. truss</p>	
 <p><b>QU30ADP021</b> Universal Adapter 29 cm square - Length 21 cm</p>	 <p><b>FP30</b> Universal 29 cm truss floor plate (30 x 30 cm)</p>	 <p><b>FP30M</b> Universal 29 cm truss large floor plate (50 x 50 cm)</p>	 <p><b>C030</b> Bar hook for 29 cm. truss</p>	



**TZ30K01**  
Assembly tool for half-spigot in 25&29cm side trusses with Heavy Duty Dado



**TZ30C01**  
Assembly tool for half-spigot in 25&29cm side trusses with Light Duty Dado



**CS029-40**  
Ceiling support for 30-40 truss series – silver



**QU3040H050**  
30-40 Special Truss L=050 with hoist support



**CL2D50**  
Transport clip. Plastic casting for truss stacking. Fits 48 - 51 mm tube



**XT-290-PC**  
Clip for cladding trusses with felt or other lightweight materials



**QU30TR**  
Lighting support



**QU30TRC**  
Lighting support diameter 100 cm



**CO30WB**  
29 cm wall bracket W/half couplers



**CBQ3040**  
4 points Bridle Hook for 29/40 cm. truss

## Dados, Corners & fittings



**QH30SAL2045**  
HD 29 cm. square 2 way 45° corner



**QH30SAL2060**  
HD 29 cm. square 2 way 60° corner

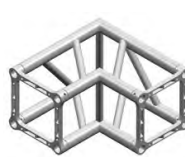

**QH30SAL2090**  
HD 29 cm. square 2 way 90° corner



**QH30SAL2120**  
HD 29 cm. square 2 ways 120° corner, ext. vertex



**QH30SAL2135**  
HD 29 cm. square 2 way 135° corner, int. vertex



**QH30SAL3**  
HD 29 cm. square 3 way corner



**QH30SAT3**  
HD 29 cm. square 3 way tee



**QH30SAT4**  
HD 29 cm. square 4 way tee



**QH30SAX4**  
HD 29 cm. square 4 way cross



**QH30SAX5**  
HD 29 cm. square 5 way cross



**QH30SAX6**  
HD 29 cm. square 6 way cross



**Q30SL2ADJ**  
Adjustable two way corner



**QU30BHH**  
Truss Hinge 29 cm square

## Heavy duty Dado



**FU30K4**  
DADO 6 way flat corner (4 nodules) K4 is the HD DADO version for square and flat section structures



**QU30K8**  
Dado 6 way box corner (8 nodules) K8 is the HD DADO version for square section structures



**QU30K8-ADP001**  
Adapter for Dado QU30K8

# QH40SA

Anti-torsion

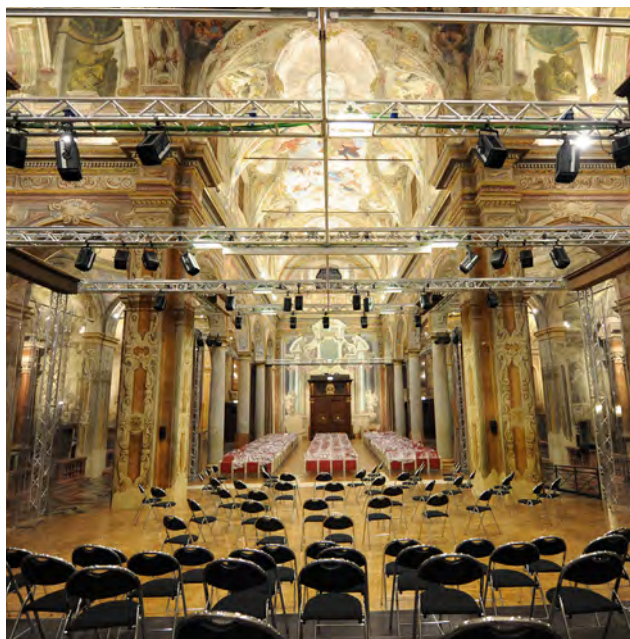

Square section heavy duty aluminium truss twist-resistant version with 40 cm long sides.

It replaces the old Heavy Duty series QD40S and QD40SA.

It is characterized by the introduction of  $\varnothing 48 \times 3$  mm chords and  $\varnothing 20 \times 2$  mm diagonals on all the faces. This truss constitutes Varitower 3-40.

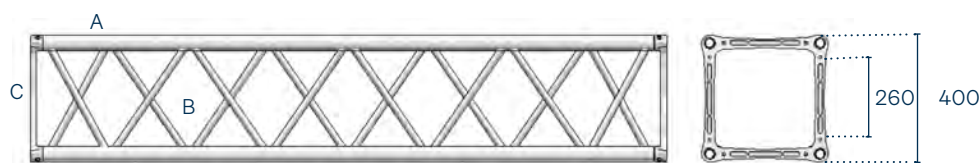

Chords A  
extruded tube  $\varnothing 48 \times 3$  mm  
EN AW-6082 T6

Diagonals B  
extruded tube  $\varnothing 22 \times 2$  mm  
EN AW-6082 T6

Ends C  
aluminium casting plate  
EN AC-42200 T6

Connection systems  
QXFC: quick-fit kit  
QXSM10: bolt connection kit

#### Linear elements

code	cm	kg
QU4OADP010	40 x 40 x 10	4.4
QH40SA025	40 x 40 x 25	5.6
QH40SA050	40 x 40 x 50	7.6
QH40SA100	40 x 40 x 100	11.3
QH40SA150	40 x 40 x 150	14.9
QH40SA200	40 x 40 x 200	18.6
QH40SA250	40 x 40 x 250	22.3
QH40SA300	40 x 40 x 300	26
QH40SA350	40 x 40 x 350	29.6
QH40SA400	40 x 40 x 400	33.3

#### Corners and fittings

code	cm	kg
FU40K4	40 x 40 x 5	4.7
QU40K8	40 x 40 x 40	12.6
QH40SAACSC	40 x 14.4 x 40	7.1
QH40SAL2045	150 x 150 x 40	11.6
QH40SAL2060	100 x 100 x 40	17.3
QH40SAL2090	50 x 50 x 40	12.6
QH40SAL2120	50 x 50 x 40	9.2
QH40SAL2135	50 x 50 x 40	9.2
QH40SAL3	50 x 50 x 50	9.5
QH40SAT3	100 x 50 x 40	14.8
QH40SAT4	100 x 50 x 50	17.3
QH40SAX4	100 x 100 x 40	20.1
QH40SAX5	100 x 100 x 50	19.9
QH40SAX6	100 x 100 x 100	27.9



### Load table / Spigot connection

SPAN	Unif. distributed load			Centre point load			Third point load			Quarter point load			Fifth point load		
	Point load	Full load	Central deflection	Point load	Full load	Central deflection	Point load	Full load	Central deflection	Point load	Full load	Central deflection	Point load	Full load	Central deflection
m	kg/m	kg	mm	kg	kg	mm	kg	kg	mm	kg	kg	mm	kg	kg	mm
1	3650	3650	0	3650	3650	0	1825	3650	0	1217	3650	0	913	3650	0
2	1822	3644	1	2822	2822	1	1736	3471	1	1215	3644	1	911	3644	1
3	1213	3638	4	2180	2180	3	1408	2815	4	1093	3279	4	907	3627	4
4	908	3631	8	1767	1767	7	1176	2353	7	936	2809	8	767	3066	9
5	693	3467	16	1480	1480	11	1006	2013	12	816	2447	14	637	2549	14
6	486	2919	23	1270	1270	16	877	1754	19	691	2073	20	544	2176	21
7	359	2515	31	1110	1110	22	775	1550	26	597	1790	28	474	1894	29
8	276	2206	41	984	984	30	693	1386	35	524	1572	37	418	1674	38
9	218	1960	52	881	881	38	625	1251	46	466	1399	47	374	1496	48
10	176	1761	65	797	797	48	569	1138	58	419	1257	59	338	1350	60
11	145	1590	79	725	725	58	521	1041	71	380	1139	72	307	1228	74
12	120	1445	94	664	664	70	479	958	85	347	1040	86	281	1123	88
13	102	1322	110	612	612	83	443	885	101	318	954	101	258	1033	104
14	87	1215	128	565	565	97	411	821	118	293	879	118	239	954	122
15	75	1122	146	524	524	112	382	765	137	271	814	135	221	885	140
16	65	1039	167	488	488	129	357	714	157	252	755	155	206	823	160
17	57	965	188	455	455	146	334	668	178	234	703	175	192	767	181
18	50	899	211	425	425	165	313	626	201	219	656	197	179	717	204

### Cantilever load table / Spigot connection

SPAN	Unif. distributed load			Centre point load	
	kg/m	kg	mm	kg	mm
1	1822	1822	1	1408	1
2	700	1400	4	880	6
3	358	1074	10	632	16
4	216	862	19	489	29
5	143	714	32	395	46
6	101	605	47	329	68

### Axial load table

SPAN	kg
m	
3	9697
6	7444
9	4316
12	2519

Load table has been prepared in accordance with UNI ENV 1999-1-1 (Eurocode 9). When calculating the allowable loads it is assumed that the load is suspended from the bottom chord and the truss is supported from the top chord at each end. The values shown in the table are the allowable static loads that can be applied to the truss. This is the live load or the payload.

The self weight of the truss has been taken into account when calculating the values in the table. It should be noted that this are idealised loading conditions and the User shall re-analyze the truss for the loading conditions which prevail for the application being considered.

To further enhance the standard products, LITEC offers a wide range of corners, connections and accessories useful for many different applications and needs. "Quick connect" or "nult & bolt connect". End-plated trusses allow to use two different systems of connection. The quick-fit system is certainly the most wide-spread and mainly used when the structure is frequently assembled and dismantled. In case of permanent installations, on the other hand, a more economical bolt connection system may be used. Our plate is made in such a way that bolts may be completely inserted so that there are no edges or external protuberances which could damage canvases or other fabrics or which might simply be unaesthetic on certain structures.

## Connections



**KSG**  
Litetruss aluminium spigot, set of 10



**KCP**  
R-spring, set of 100



**KSP**  
Steel pin, set of 10



**K370**  
Half truss spigot + 1 steel pin + 1 R-spring (not for Dado)



**KSFH / KSN**  
Threaded pin, set of 12/  
Threaded pin, set of 10



**KCFS**  
Kit for vert. connec. incl. bolts, spigots and accessories



**QXFC**  
Quick connection set for Q Series



**QXSM10\***  
Bolt connection set for 30 - 40 series

**\* Achtung!**  
werden nur die Schraubverbinder eingesetzt, verringert sich die Tragkraft um 50%



**QUKFC**  
4 special steel half spigots with screws for Heavy Duty Dado

## Accessories



**QH40SAACSC**  
ST 40 cm. square  
Clamp module  
Towerlift/Varitower



**QU40ADP010**  
Universal Adapter  
29 cm. square  
Length 10 cm



**CO40**  
Bar hook for 40 cm truss



**FP40**  
Universal 40 cm truss floor plate (40 x 40 cm)



**FP30M**  
Universal 40 cm truss large floor plate (50 x 50 cm)



**CL2D50**  
Transport clip. Plastic casting for truss stacking.  
Fits 48 - 51 mm tube



**TZ40K01**  
Assembly tool for half-spigot in 40 cm side trusses with Heavy Duty Dado



**TZ40C01**  
Assembly tool for half-spigot in 40 cm side trusses with Light Duty Dado



**CBQ3040**  
4 points Bridle Hook for 29/40 cm truss



**QU3040H050**  
30-40 Special Truss L=050 with hoist support





**CS029-40**  
Ceiling support for 30-40 truss series – silver



**CBT3040**  
2 points Bridle Hook for 29/40 cm. truss

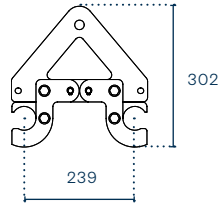

## Dados, Corners & fittings



**QH40SAL2045**  
HD 40 cm. square  
2 way 45° corner



**QH40SAL2060**  
HD 40 cm. square  
2 way 60° corner

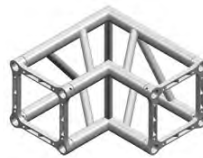

**QH40SAL2090**  
HD 40 cm. square  
2 way 90° corner



**QH40SAL2120**  
HD 40 cm. square 2 ways  
120° corner, ext. vertex



**QH40SAL2135**  
HD 40 cm. square 2 way 135°  
corner, int. vertex



**QH40SAL3**  
HD 40 cm. square  
3 way corner



**QH40SAT3**  
HD 40 cm. square  
3 way tee



**QH40SAT4**  
HD 40 cm. square  
4 way tee

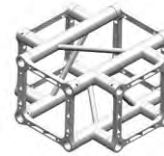

**QH40SAX4**  
HD 40 cm. square  
4 way cross



**QH40SAX5**  
HD 40 cm. square  
5 way cross



**QH30SAX6**  
HD 29 cm. square  
6 way cross



**Q40SL2ADJ**  
Adjustable 2 way corner

## Heavy duty Dado



**FU40K4**  
DADO 6 way flat corner  
(4 nodules) K4 is the HD  
DADO version for square and  
flat section structures



**QU40K8**  
Dado 6 way box corner  
(8 nodules) K8 is the HD DADO  
version for square section  
structures

# RH40SA



RH40SA is on the front line of rectangular truss that meets the needs of your demanding projects, as it has been specifically developed for applications that require heavy-duty performance. A perfect choice for rental companies, it features LITEC's end plated connection system for greater resistance to twisting, decrease in bending and absolute connection compatibility between other trusses throughout the years due to no risk of deformation.

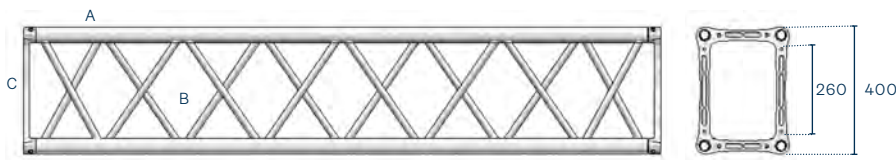

Chords A  
Extruded tube  $\varnothing$  48 x 3 mm  
EN AW – 6082 T6

Diagonals B  
Extruded tube  $\varnothing$  22 x 2 mm  
EN AW – 6082 T6

End C  
Aluminium casting plate  
EN AC – 42200 KT6

Connection systems  
QXFC: quick-fit kit

## Linear elements

code	cm	kg
RH40SA010	40 x 29 x 10	4.4
RH40SA025	40 x 29 x 25	5.6
RH40SA050	40 x 29 x 50	7.6
RH40SA100	40 x 29 x 100	11.3
RH40SA150	40 x 29 x 150	14.9
RH40SA200	40 x 29 x 200	18.6
RH40SA250	40 x 29 x 250	22.3
RH40SA300	40 x 29 x 300	26.0
RH40SA350	40 x 29 x 350	29.6
RH40SA400	40 x 29 x 400	33.3

## Corners and fittings

code	cm	kg
RH40K8	40 x 29 x 29	10.6
RH40K12	40 x 29 x 29	13.0

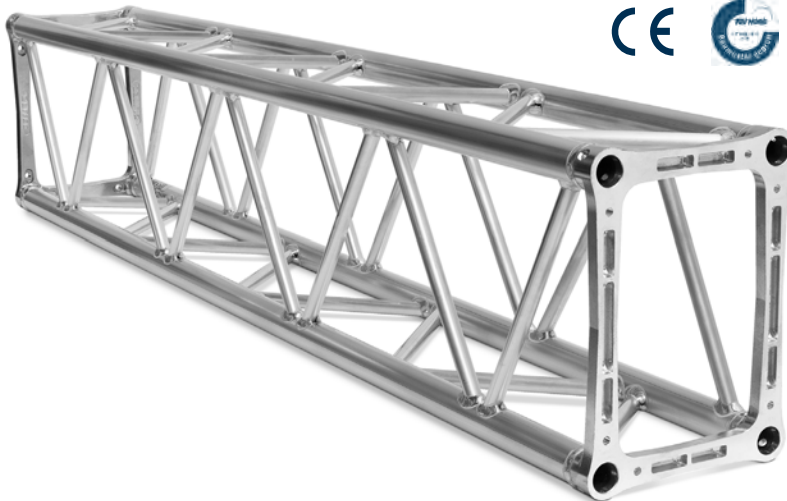

### Load table / Spigot connection

SPAN	Unif. distributed load			Centre point load			Third point load			Quarter point load			Fifth point load		
	Point load	Full load	Central deflection	Point load	Full load	Central deflection	Point load	Full load	Central deflection	Point load	Full load	Central deflection	Point load	Full load	Central deflection
m	kg/m	kg	mm	kg	kg	mm	kg	kg	mm	kg	kg	mm	kg	kg	mm
1	3175	3175	0	3043	3043	0	1588	3175	0	1058	3175	0	794	3175	0
2	1584	3168	1	2389	2389	2	1390	2780	2	1012	3036	2	792	3168	2
3	1054	3162	5	1977	1977	5	1191	2382	5	887	2662	5	717	2869	5
4	789	3155	11	1688	1688	9	1044	2088	10	792	2376	10	648	2594	11
5	630	3148	21	1460	1460	16	929	1857	17	715	2146	18	592	2369	19
6	450	2700	32	1236	1236	23	837	1674	27	648	1944	29	524	2094	30
7	329	2302	43	1069	1069	32	761	1522	39	556	1668	40	451	1806	41
8	250	2001	56	939	939	43	680	1359	52	485	1455	52	396	1584	54
9	196	1766	71	835	835	55	608	1216	67	430	1289	66	352	1407	69
10	158	1576	88	750	750	68	549	1097	84	385	1154	82	316	1262	86
11	129	1420	107	679	679	83	499	997	102	347	1042	100	286	1142	104
12	107	1289	127	619	619	100	456	912	123	316	947	119	260	1040	124
13	91	1177	149	567	567	118	419	838	145	289	866	140	238	953	147
14	77	1080	174	522	522	138	387	773	170	265	796	163	219	876	171
15	66	994	199	481	481	159	358	716	196	245	734	188	202	809	197
16	57	919	227	446	446	182	333	665	225	227	680	214	187	749	224
17	50	852	257	414	414	207	310	619	255	210	630	243	174	696	254
18	44	791	289	385	385	234	289	578	287	195	586	273	162	648	286

### Cantilever load table / Spigot connection

SPAN	Point load	Full load	Central deflection	Point load	Central deflection
	kg/m	kg	mm		kg
1	151	151	1	119	2
2	591	118	5	838	9
3	324	971	14	616	23
4	205	820	28	468	42
5	141	704	47	373	66
6	98	586	70	308	96

### Axial load table

m	kg
1	14100
2	11900
3	8850
4	6220
5	4440

Load table has been prepared in accordance with din4113 and DIN18800. When calculating the allowable loads it is assumed that the load is suspended from the bottom chord and the truss is supported from the top chord at each end. The values shown in the table are the allowable static loads that can be applied to the truss. This is the live load or the payload. The self-weight of the truss has been taken into account when calculating the values in the table.

It should be noted that this are idealized loading conditions and the User shall re-analyze the truss for the loading conditions which prevail for the application being considered.

To further enhance the standard products, LITEC offers a wide range of corners, connections and accessories useful for many different applications and needs. "Quick connect" or "nult & bolt connect". End-plated trusses allow to use two different systems of connection. The quick-fit system is certainly the most wide-spread and mainly used when the structure is frequently assembled and dismantled. In case of permanent installations, on the other hand, a more economical bolt connection system may be used. Our plate is made in such a way that bolts may be completely inserted so that there are no edges or external protuberances which could damage canvases or other fabrics or which might simply be unaesthetic on certain structures.

## Connections



**KSG**  
Litecstruss aluminium spigot, set of 10



**KCP**  
R-spring, set of 100



**KSP**  
Steel pin, set of 10

**K370-4**  
Half truss spigot + 1 steel pin + 1 R-spring (not for Dado)



**KSFH / KSN**  
Threaded pin, set of 12  
Threaded pin, set of 10



**KCFS**  
Kit for vert. connec incl. bolts, spigots and accessories



**QXFC**  
Quick connection set



**QXSM10**  
Bolt connection set for 30-40 series

**\* Achtung!**  
werden nur die Schraubverbinder eingesetzt, verringert sich die Tragkraft um 50%



**QUKFC**  
4 special steel half spigots with screws for Heavy Duty Dado

## Accessories



**CS029-40**  
Ceiling support for 30-40 truss series – silver



**CBQ3040**  
4 points Bridle Hook for 29/40 cm. truss



**CL2D50**  
Transport clip. Plastic casting for truss stacking. Fits 48 - 51 mm tube



**CBT3040**  
2 points Bridle Hook for 29/40 cm. truss

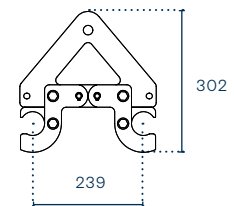

**C030**  
Bar hook for 29 cm. truss

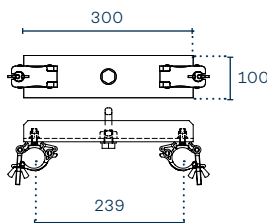

## Corners & fittings

---



**RU40K8**  
Dado 6 way box corner  
(8 nodules)



**RU40K12**  
Dado 6 way box corner  
(12 nodules)



# LiteCAD Evolution

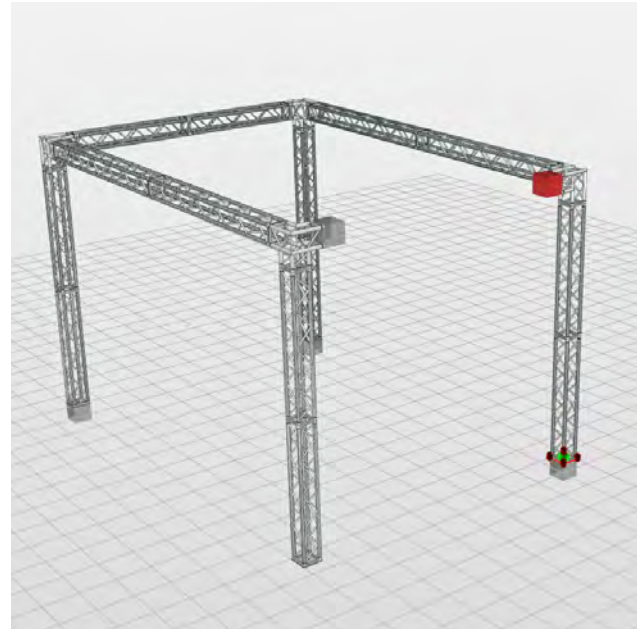

- ◆ The LiteCAD Evolution is currently supporting the truss models **QX25SA, QX30SA, QX40SA, QH30SA & QH40SA.**
- ◆ LiteCAD Evolution was conceived to meet the needs of technicians who work in the entertainment business, in theatres, in TV studios, in trade fairs and everywhere our aluminium trusses are used.

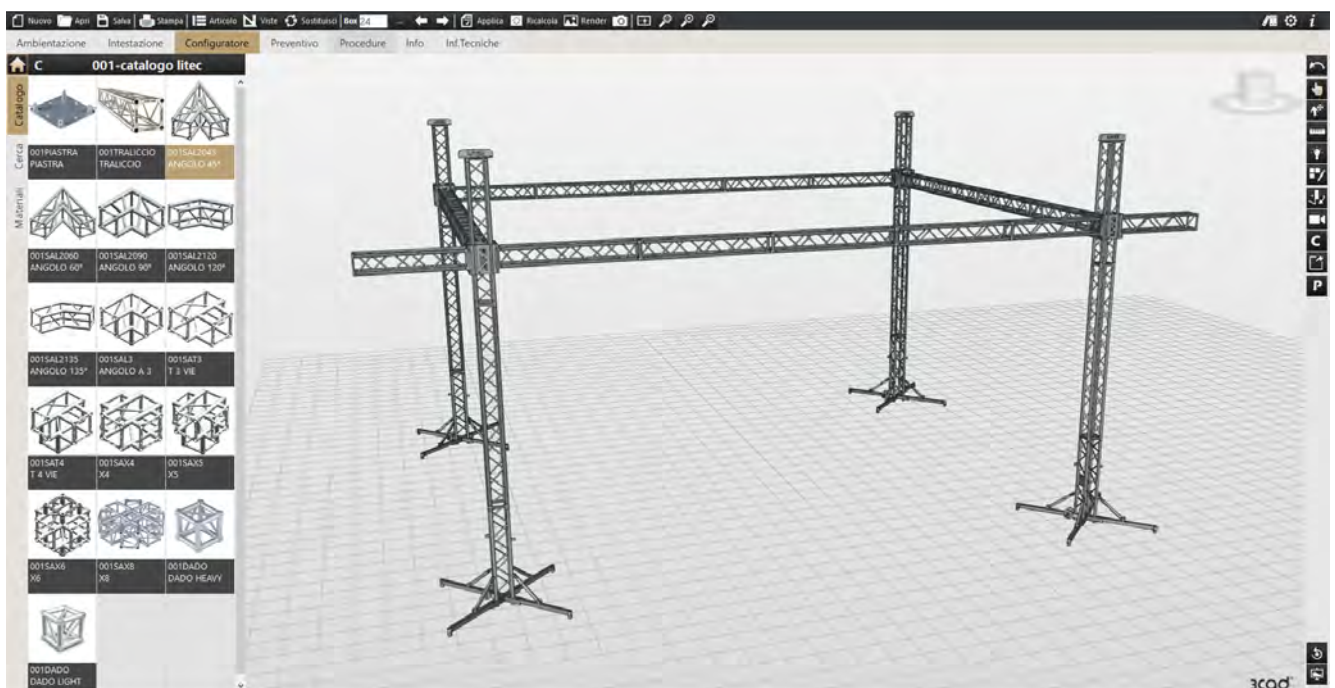

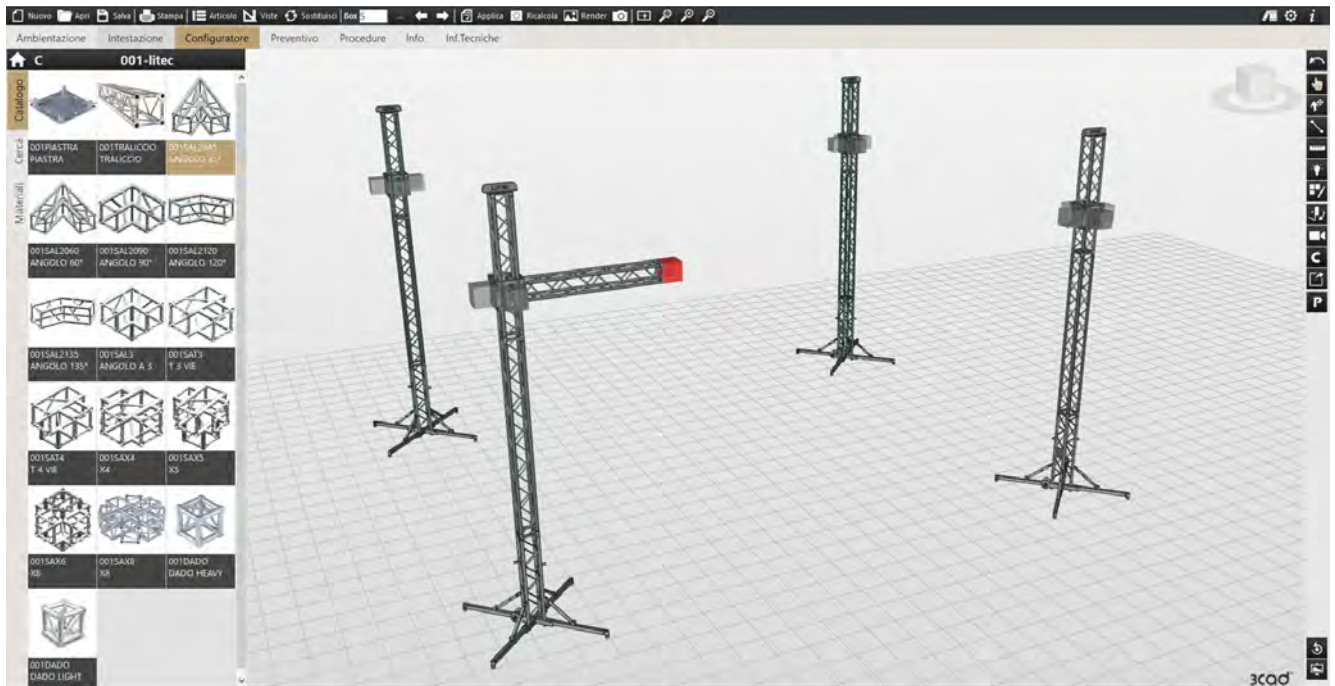

- ◆ LiteCAD Evolution is a **user-friendly Computer-Aided Design program** specifically engineered to configure Litec Truss and relevant accessories in multiple applications.
- ◆ With this software, technicians are quickly able to **put together the structure they have in mind** and propose it to their clients. Furthermore, **it instantly draws up a list of the components needed**, with technical data, such as weight and space occupied. It is possible to upload dxf files such as theatre drawings and build up a structure. All this without needing any specialist knowledge of the CAD world.
- ◆ For further information and updates on its potential, please contact our Engineering Department.

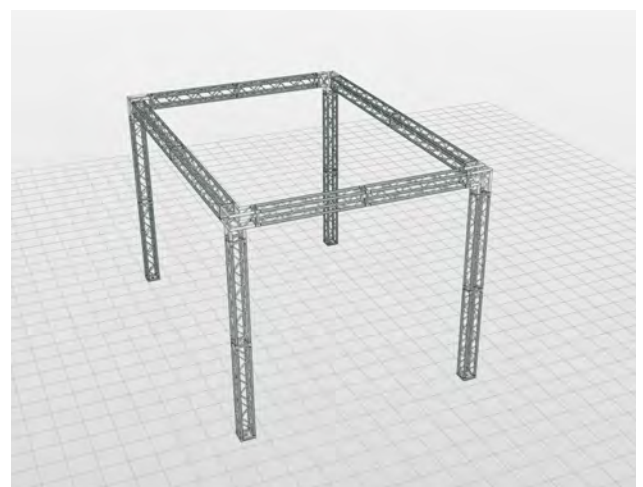
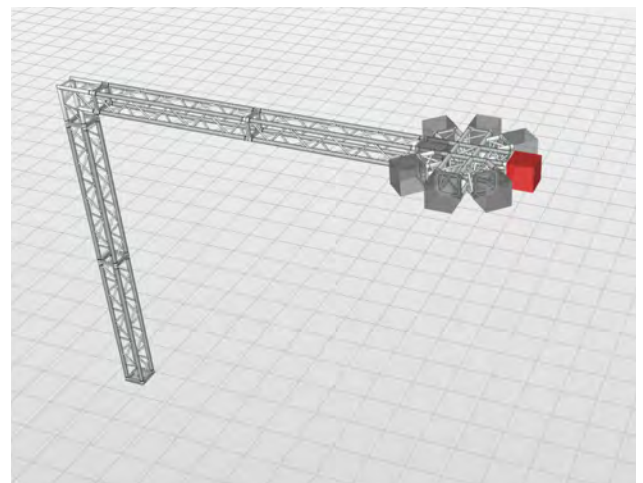









# LIBERA STAR

## High Load Trusses

### **Infinity, in a few cubic meters**

---

LIBERA is the only flat aluminium beam system in the world that can easily be used to create and build load-bearing structures in a virtually infinite number of shapes. LIBERA System consists of “constant” elements, FL52, FL76 and FL105 flat beams, and “variable” elements which make it extremely versatile. LIBERA is compact, modular, strong, reliable, easy to transport and store. LIBERA cuts your running costs to a minimum. LIBERA roofing sheets are available in various lengths, finishings and colours. LIBERA can also easily combine with the High Load truss range with forked connections.

# LIBERA FL52



This is the most suitable LIBERA system for fairs and medium-sized installations. This modular grid structure can be used to build single spans of up to 16/18 meters in length with standard centre-to-centre distances (50 cm, 1 and 2 meters).

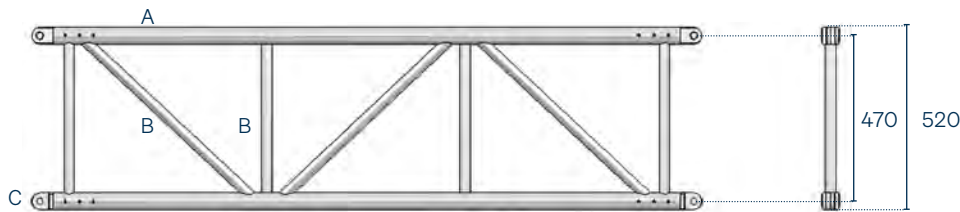

Chords A  
Extruded tube Ø 50 x 4 mm  
EN AW – 6082 T6

Diagonals B  
Extruded tube Ø 30 x 3 mm  
EN AW – 6082 T6

Ends C  
forks connector  
EN AW – 6082 T6

Connection system  
FL52C504: four-way connection  
KHL P: cylindrical pin + safety R-clip KHL M+KHL F

## LIBERA system FL52

33 to 186 cm flat trusses – FL52

Available in two versions: standard and with built-in roofing sheet guides

Ends with aluminium forks

Made of EN AW-6082 T6 aluminium with 50 x 4 mm tubes and 30 x 30 mm diagonals

Universal four-way connection

## Truss

code	H cm	L cm
FL52035V	flat section 52	35
FL52086V	flat section 52	86
FL52137V	flat section 52	137
FL52186V	flat section 52	186
FL52035R	flat section 52	35 with guide
FL52086R	flat section 52	86 with guide
FL52186R	flat section 52	186 with guide



### Load table

SPAN	Unif. distributed load			Centre point load			Third point load			Quarter point load			Fifth point load		
	Point load	Full load	Central deflection	Point load	Full load	Central deflection	Point load	Full load	Central deflection	Point load	Full load	Central deflection	Point load	Full load	Central deflection
	m	kg/m	kg	mm	kg	kg	mm	kg	kg	mm	kg	kg	mm	kg	kg
5	372	1859	7	930	930	5	697	1395	7	465	1395	6	387	1549	7
6	256	1536	10	768	768	8	576	1152	10	384	1152	9	320	1280	10
7	186	1303	13	651	651	11	489	977	14	326	977	13	271	1086	13
8	141	1126	17	563	563	14	422	845	18	282	845	17	235	939	17
9	110	987	22	494	494	18	370	740	22	247	740	21	206	823	22
10	87	875	27	437	437	22	328	656	28	219	656	26	182	729	27
11	71	781	33	391	391	27	293	586	34	195	586	31	163	651	33
12	58	702	39	351	351	32	263	526	40	175	526	38	146	585	40
13	49	634	46	317	317	38	238	475	47	158	475	44	132	528	47
14	41	574	54	287	287	45	215	431	55	144	431	52	120	479	54
15	35	522	62	261	261	52	196	391	63	130	391	59	109	435	62
16	30	475	71	238	238	59	178	356	72	119	356	68	99	396	71
17	25	433	80	216	216	68	162	325	81	108	325	77	90	361	80
18	22	395	90	197	197	77	148	296	91	99	296	87	82	329	90
19	19	360	100	180	180	86	135	270	102	90	270	97	75	300	101
20	16	327	112	164	164	97	123	245	113	82	245	108	68	273	112
21	14	297	123	149	149	108	111	223	125	74	223	120	62	248	124
22	12	269	136	135	135	120	101	202	138	67	202	132	56	225	137
23	11	243	149	122	122	132	91	183	151	61	183	145	51	203	150
24	9	219	163	109	109	146	82	164	165	55	164	159	46	182	164
25	8	196	178	98	98	160	73	147	180	49	147	173	41	163	178

### Cantilever load table

SPAN	Unif. distributed load			Centre point load		
	Point load	Full load	Central deflection	Point load	Full load	Central deflection
	m	kg/m	kg	mm	kg	kg
1.0	1156	1156	0	1101	1101	1
1.5	768	1152	1	785	785	2
2.0	546	1092	2	585	585	3
2.5	372	930	4	465	465	5
3.0	256	768	6	384	384	8
3.5	186	651	8	326	326	11
4.0	141	563	10	282	282	14

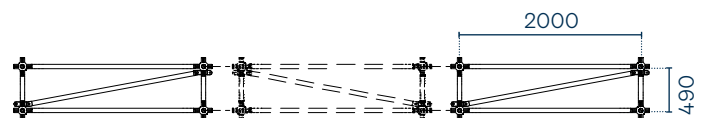

These load capacity values are only valid if the trusses are connected together every 2 metres (Lo)  
The load capacity values are only valid for a single line.

# LIBERA FL52

## System

LIBERA is an open structural system. The distinguishing feature of the system is that it uses standard modular elements connected together in ways that allow varied design and geometry of the finished structure. These two pages show connections and accessories that are helpful in the assembly or set up of your LIBERA FL52 system. The wide range of accessories for LIBERA System include bar hooks, spacers for the construction of arched geometries, complimentary elements for sleeve-blocks and transport trolley systems for flat trusses.

## Connections



**KHLB**  
M20 screw bolt  
+ spring washer

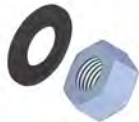

**KHLD**  
M20 screw nut  
+ spring washer



**KHLF**  
Female fork connector  
complete



**KHLG**  
M20 Lifting Eye



**KHLM**  
Male fork  
connector complete



**KHLP**  
Cylindrical pin  
+ 3 mm safety R-clip



**KHL180A**  
180° double fork  
aluminum connector



**KHL180S**  
180° double fork  
steel connector



**KHL90LA**  
90° double fork  
alum. connector, left



**KHL90LS**  
90° double fork steel  
connector, left



**KHL90RA**  
90° double fork alum.  
connector, right



**KHL90RS**  
90° double fork steel  
connector, right



**KHL180AL149R**  
Alusfera 76 spacer A



**FL52CS02**  
2-way fork connection  
system



**FL52CS03**  
3-way fork connection  
system



**FL52CS04**  
4-way fork connection  
system



**FL52CS04C**  
4-way fork conn. system  
rounded end



**FL52CS04L**  
4-way fork  
conn. system w/foot



**FL52CS04R**  
4-way fork conn.  
system w/foot  
and vertical fork



**TZHL01**  
FL assembly kit

## Accessories



**C052D**  
Bar hook  
for 52 cm. truss



**FL52033HSZ1**  
Hoist support



**FL52047HSZ1**  
Hoist support



**FL52ST**  
FL52 Transport  
trolley system  
for 20 pieces



**FL52MS**  
Hoist support



**FL52IS40-L**  
Inclination system  
for MT52 tower/Libera  
52 - Left



**FL52IS40-R**  
Inclination system  
for MT52 tower/Libera  
52 - Right



**RA / Reinforcement arm**  
RA050 – working length 73 cm  
RA100 – working length 123 cm  
RA200 – working length 223 cm  
RA300 – working length 323 cm



**RAF / Reinforced tube w/forks**  
RAF047 – working length 47 cm  
RAF086 – working length 86 cm  
RAF100 – working length 100 cm  
RAF186 – working length 186 cm  
RAF200 – working length 200 cm



**RAH / Diagonal brace w/hooks**  
RAH014M2P – working length 14.2 cm  
RAH049P – working length 49 cm  
RAH141M4 – working length 141 cm  
RAH158M8 – working length 158 cm  
RAH205M9S – working length 205 cm  
RAH213M5 – working length 213 cm  
RAH223M6 – working length 223 cm  
RAH250M6 – working length 250 cm  
RAH282M8 – working length 282 cm



**RAL / Aluminium pipe**  
RAL047 – length 47 cm  
RAL086 – length 86 cm  
RAL100 – length 100 cm  
RAL186 – length 186 cm  
RAL200 – length 200 cm



**RAT / Aluminium pipe w/caps**  
RAT050 – working length 50 cm  
RAT100 – working length 100 cm  
RAT150 – working length 150 cm  
RAT200 – working length 200 cm  
RAT250 – working length 250 cm  
RAT300 – working length 300 cm

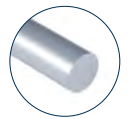

## Frames

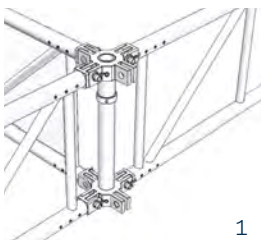

1

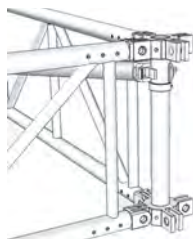

2

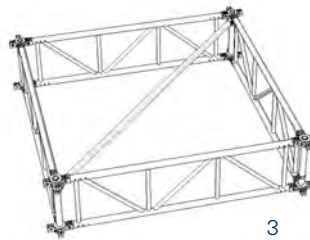

3

1 / FL52 truss fixed onto 4-way  
connection system FL52CS04

2 / Detail of RAH fixed onto FL52 end  
brace

3 / FL52 module

# LIBERA FL76



This LIBERA System is ideal for large grids and complex installations, allowing to build structures of up to 22 metres long with standard centre-to-centre distances. Indoors, it is suitable for theatre grid structures, and TV and cinema studios with innumerable advantages.

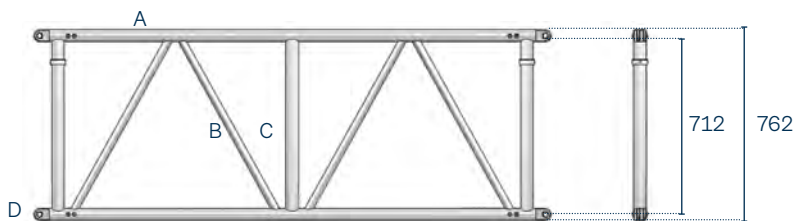

Chords A  
Extruded tube  $\varnothing$  50 x 4 mm  
EN AW – 6082 T6

Diagonals B  
Extruded tube  $\varnothing$  30 x 3 mm  
EN AW – 6082 T6

Braces C  
Extruded tube  $\varnothing$  50 x 4 mm  
EN AW – 6082 T6

Ends D  
steel forks connector  
11SMnPb37

Connection system  
KHLP: Cylindrical pin + safety  
R-clip KHLM+KHLF

## LIBERA system FL76

47 to 200 cm flat trusses – FL56

Available in two versions: standard and with built-in roofing sheet guides

Ends with aluminium forks

50 x 4 mm tubes and 30 x 3 mm diagonals made from EN AW-6082 T6 aluminium

Curved parts for grid structure end fittings

Universal four-way connection

## Truss

code	H cm	L cm
FL76047V	flat section 76	47
FL76086V	flat section 76	86
FL76100V	flat section 76	100
FL76186V	flat section 76	186
FL76200V	flat section 76	200
FL76047R	flat section 76	47 with guide
FL76086R	flat section 76	86 with guide
FL76100R	flat section 76	100 with guide
FL76186R	flat section 76	186 with guide
FL76200R	flat section 76	200 with guide
FL76111RHC	flat section 76	105 curved

\*V - standard truss

\*R - built-in rail for canopy





### Load table / Type A

4-WAY STAR CONNECTION



SPAN	Unif. distributed load			Centre point load		
	Point load	Full load	Central deflection	Point load	Full load	Central deflection
m	kg/m	kg	mm	kg	kg	mm
3	818	2453	1	2118	2118	1
4	610	2441	2	1579	1579	2
5	486	2430	4	1253	1253	3
6	344	2067	6	1033	1033	5
7	250	1750	8	875	875	6
8	189	1510	10	755	755	8
9	147	1320	13	660	660	11
10	117	1167	16	583	583	13
11	94	1039	19	519	519	16
12	78	930	23	465	465	19
13	64	836	27	418	418	23
14	54	755	32	377	377	27
15	45	682	37	341	341	31
16	39	617	42	309	309	36
17	33	559	47	279	279	41
18	28	505	53	253	253	46
19	24	456	60	228	228	52
20	21	411	66	206	206	58
21	18	369	73	185	185	65
22	15	330	81	165	165	72
23	13	293	89	147	147	80
24	11	259	97	129	129	88

### Load table / Type B

MALE/FEMALE FORK CONNECTION



SPAN	Unif. distributed load			Centre point load		
	Point load	Full load	Central deflection	Point load	Full load	Central deflection
m	kg/m	kg	mm	kg	kg	mm
3	462	1387	0	1387	1387	1
4	344	1375	1	1375	1375	2
5	273	1364	2	1253	1253	3
6	225	1352	4	1033	1033	5
7	192	1341	6	875	875	6
8	166	1329	9	755	755	8
9	146	1318	13	660	660	11
10	117	1167	16	583	583	13
11	94	1039	19	519	519	16
12	78	930	23	465	465	19
13	64	836	27	418	418	23
14	54	755	32	377	377	27
15	45	682	37	341	341	31
16	39	617	42	309	309	36
17	33	559	47	279	279	41
18	28	505	53	253	253	46
19	24	456	60	228	228	52
20	21	411	66	206	206	58
21	18	369	73	185	185	65
22	15	330	81	165	165	72
23	13	293	89	147	147	80
24	11	259	97	129	129	88

### Cantilever load table / Type A



SPAN	Unif. distributed load			Centre point load		
	Point load	Full load	Central deflection	Point load	Full load	Central deflection
m	kg/m	kg	mm	kg	kg	mm
1.0	1232	1232	0	1232	1232	0
1.5	818	1226	1	1057	1057	1
2.0	610	1221	1	787	787	2
2.5	486	1215	2	625	625	3
3.0	344	1031	3	515	515	5
3.5	249	873	5	436	436	6
4.0	188	753	6	377	377	8

### Cantilever load table / Type B



SPAN	Unif. distributed load			Centre point load		
	Point load	Full load	Central deflection	Point load	Full load	Central deflection
m	kg/m	kg	mm	kg	kg	mm
1.0	699	699	0	699	699	0
1.5	462	693	0	693	693	1
2.0	344	688	1	688	688	2
2.5	273	682	1	625	625	3
3.0	225	676	2	515	515	5
3.5	192	670	4	436	436	6
4.0	166	665	5	377	377	8

# LIBERA FL76

## System

LIBERA is an open structural system. The distinguishing feature of the system is that it uses standard modular elements connected together in ways that allow varied design and geometry of the finished structure. These two pages show connections and accessories that are helpful in the assembly or set up of your LIBERA FL76 system. The wide range of accessories for LIBERA System include bar hooks, spacers for the construction of arched geometries, complimentary elements for sleeve-blocks and transport trolley systems for flat trusses.

## Connections



**KHLB**  
M20 screw bolt  
+ spring washer



**KHLD**  
M20 screw nut  
+ spring washer



**KHLF**  
Female fork connector  
complete



**KHLG**  
M20 Lifting Eye



**KHLM**  
Male fork  
connector complete



**KHLP**  
Cylindrical pin  
+ 3 mm safety R-clip



**KHL180A**  
180° double fork  
aluminum connector



**KHL180S**  
180° double fork  
steel connector



**KHL90LA**  
90° double fork  
alum. connector, left



**KHL90LS**  
90° double fork steel  
connector, left



**KHL90RA**  
90° double fork alum.  
connector, right



**KHL90RS**  
90° double fork steel  
connector, right



**KHL180AL149R**  
Alusfera 76 spacer A



**FL76CS02**  
2-way fork connection  
system



**FL76CS03**  
3-way fork connection  
system



**FL76CS04**  
4-way fork connection  
system



**FL76CS04C**  
4-way fork conn. system  
rounded end



**FL76CS04L**  
4-way fork  
conn. system w/foot



**FL76CS04Z1**  
4-way cross special  
connection



**FL76CS04Z2**  
4-way cross special  
connection



**FL76CS04R**  
4-way fork conn.  
system w/foot  
and vertical fork



**TZHL01**  
FL assembly kit

# Accessories



**C052D**  
Bar hook  
for 52 cm. truss



**C066**  
Bar hook  
for 61 cm. truss



**FL76059HS**  
HL 76 cm. gate  
cm 59 truss -  
hoist support



**FL76047HSV**  
HL 76 cm. gate  
cm 47 truss -  
hoist support



**FL76MSZ1**  
Hoist support



**FLRS52E-L**  
Inclination system  
for MT52 tower/Libera  
76 - Left



**FLRS52E-R**  
Inclination system  
for MT52 tower/  
Libera 76 - Right



**FLRS40E-L**  
Inclination system  
for MT40 tower/  
Libera 76 - Left



**FLRS40E-R**  
Inclination system  
for MT40 tower/  
Libera 76 - Right



**FL76ST**  
FL76 transport trolley  
system for 20 pieces



**FL76FP**  
Stage floor plate



**FL76TT**  
Support for truss



**RA / Reinforcement arm**  
RA050 – working length 73 cm  
RA100 – working length 123 cm  
RA200 – working length 223 cm  
RA300 – working length 323 cm



**RAF / Reinforced tube w/forks**  
RAF047 – working length 47 cm  
RAF086 – working length 86 cm  
RAF100 – working length 100 cm  
RAF186 – working length 186 cm  
RAF200 – working length 200 cm



**RAH / Diagonal brace w/hooks**  
RAH014M2P – working length 14.2 cm  
RAH049P – working length 49 cm  
RAH141M4 – working length 141 cm  
RAH158M8 – working length 158 cm  
RAH205M9S – working length 205 cm  
RAH213M5 – working length 213 cm  
RAH223M6 – working length 223 cm  
RAH250M6 – working length 250 cm  
RAH282M8 – working length 282 cm



**RAL / 4 mm Aluminium pipe**  
RAL047 – length 47 cm  
RAL086 – length 86 cm  
RAL100 – length 100 cm  
RAL186 – length 186 cm  
RAL200 – length 200 cm



**RAT / Aluminium pipe w/caps**  
RAT050 – working length 50 cm  
RAT100 – working length 100 cm  
RAT150 – working length 150 cm  
RAT200 – working length 200 cm  
RAT250 – working length 250 cm  
RAT300 – working length 300 cm

# Frames

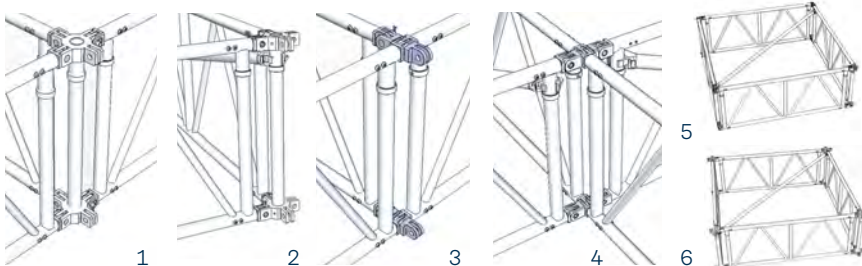

1 / FL76 truss  
fixed onto 4-way  
connection system  
FL76CS04

4 / Detail of FL76  
module with RAH  
fixed onto end brace

2 / Detail RAH fixed  
onto FL76 end  
brace

5 / FL76 module  
with RAH fixed onto  
end brace

3 / FL76 truss fixed  
onto end brace  
KHLM + KHLF

6 / FL76 module  
with 4-way  
connection

# LIBERA FL105



The top of the LIBERA range. It is ideal for heavy duty use, with High Load carrying capacity and wide spans. LIBERA 105 is mainly for outdoor use. It is the most suitable system for building roofing and large structures. It can be used to build a span of up to 30 metres in length with a large carrying capacity.

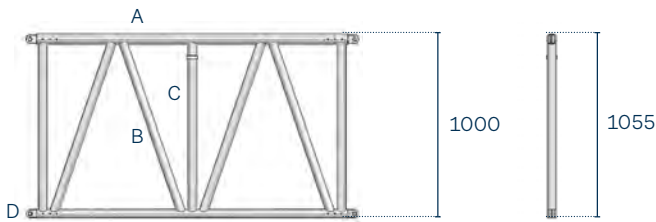

Upper chords A  
Extruded tube Ø 60 x 5 mm  
EN AW – 6082 T6

Lower chords A  
Extruded tube Ø 50 x 5 mm  
EN AW – 6082 T6

Diagonals B  
Extruded tube Ø 50 x 4 mm  
EN AW – 6082 T6

Braces C  
Extruded tube Ø 50 x 4 mm  
EN AW – 6082 T6

Ends D  
forks connector  
EN AW – 6082 T6

Connection system  
KHLF: Cylindrical pin + safety  
R-clip KHLM+KHLF

## Truss

code	H cm	L cm
FL105045V	flat section 105	45
FL105086V	flat section 105	86
FL105136V	flat section 105	136
FL105186V	flat section 105	186

## LIBERA system FL105

45 to 186 cm flat trusses – FL105

Available in standard versions

Ends with aluminium forks

Made of EN AW-6082 T6 aluminium with 60 x 5 mm upper tube, 50 x 4 mm lower tube and 50 x 4 mm diagonal

Universal four-way or male/female pass through connection

## Cantilever load table



SPAN	Unif. distributed load			Centre point load		
	Point load	Full load	Central deflection	Point load	Full load	Central deflection
m	kg/m	kg	mm	kg	kg	mm
1.0	1270	1270	0	1270	1270	0
2.0	627	1254	0	1129	1129	1
3.0	410	1229	1	859	859	3
4.0	273	1091	3	630	630	5
5.0	195	975	5	490	490	7
5.5	159	875	7	438	438	9
6.0	131	787	8	393	393	10



### Load table

SPAN	Unif. distributed load			Centre point load			Third point load			Quarter point load			Fifth point load		
	Point load	Full load	Central deflection	Point load	Full load	Central deflection	Point load	Full load	Central deflection	Point load	Full load	Central deflection	Point load	Full load	Central deflection
m	kg/m	kg	mm	kg	kg	mm	kg	kg	mm	kg	kg	mm	kg	kg	mm
5	499	2493	1	2491	2491	2	1246	2493	2	831	2493	2	623	2493	2
6	413	2477	2	2277	2277	3	1238	2477	3	826	2477	3	619	2477	3
7	351	2460	4	1996	1996	5	1230	2460	5	820	2460	5	615	2460	4
8	306	2444	6	1731	1731	6	1187	2373	7	815	2444	7	611	2444	7
9	270	2428	8	1524	1524	8	1114	2229	10	762	2285	9	607	2428	10
10	241	2412	11	1356	1356	10	1017	2034	12	678	2034	12	656	2260	12
11	218	2396	15	1217	1217	12	913	1826	15	609	1826	14	507	2029	15
12	183	2201	18	1101	1101	14	825	1651	18	550	1651	17	459	1834	18
13	154	201	21	1000	1000	17	750	1501	21	500	1501	20	417	1667	21
14	131	1827	24	914	914	20	685	1370	25	457	1370	23	381	1523	24
15	112	1674	28	837	837	23	628	1256	28	419	1256	26	349	1395	28
16	96	1538	32	769	769	26	577	1154	32	385	1154	30	321	1282	32
17	83	1417	36	708	708	30	531	1063	36	354	1063	34	295	1181	36
18	73	1307	40	653	653	34	490	980	41	327	980	38	272	1089	40
19	64	1207	45	603	603	38	453	905	45	302	905	43	251	1006	45
20	56	1115	50	558	558	42	418	836	51	279	836	48	232	929	50
21	49	1031	55	515	515	47	387	773	56	258	773	53	215	859	55
22	43	953	60	476	476	52	357	714	61	238	714	58	198	794	61
23	38	880	66	440	440	57	330	660	67	220	660	64	183	733	67
24	34	812	72	406	406	63	304	609	73	203	609	70	169	676	73
25	30	748	79	374	374	69	280	561	80	187	561	76	156	623	79
26	26	687	85	344	344	75	258	516	86	172	516	83	143	573	86
27	23	630	92	315	315	82	236	473	93	158	473	90	131	525	93
28	21	576	100	288	288	89	216	432	101	144	432	97	120	480	100
29	18	525	107	262	262	96	197	394	108	131	394	105	109	437	108
30	16	476	115	238	238	104	178	357	116	119	357	112	99	397	116

These load capacity values are only valid if the trusses are connected together every 2 metres (L<sub>0</sub>)  
 The load capacity values are only valid for a single line.

# LIBERA FL105

## System

LIBERA is an open structural system. The distinguishing feature of the system is that it uses standard modular elements connected together in ways that allow varied design and geometry of the finished structure. These two pages show connections and accessories that are helpful in the assembly or set up of your LIBERA FL105 system. The wide range of accessories for LIBERA System include bar hooks, spacers for the construction of arched geometries, complimentary elements for sleeve-blocks and transport trolley systems for flat trusses.

## Connections



**KHLB**  
M20 screw bolt  
+ spring washer



**KHLD**  
M20 screw nut  
+ spring washer



**KHLF**  
Female fork connector  
complete



**KHLG**  
M20 Lifting Eye



**KHLM**  
Male fork  
connector complete



**KHLP**  
Cylindrical pin  
+ 3 mm safety R-clip



**KHL180A**  
180° double fork  
aluminum connector



**KHL180S**  
180° double fork  
steel connector



**KHL90LA**  
90° double fork  
alum. connector, left



**KHL90LS**  
90° double fork steel  
connector, left



**KHL90RA**  
90° double fork alum.  
connector, right



**KHL90RS**  
90° double fork steel  
connector, right



**KHL180AL149R**  
Alusfera 76 spacer A



**FL105CS02**  
2-way fork connection  
system



**FL105CS03**  
3-way fork connection  
system



**FL105CS04**  
4-way fork connection  
system



**FL105CS04C**  
4-way fork conn. system  
rounded end



**FL105CS04L**  
4-way fork  
conn. system w/foot



**FL105CS04Z1**  
4-way cross special  
connection



**FL105CS04R**  
4-way fork conn.  
system w/foot  
and vertical fork



**TZHL01**  
FL assembly kit

## Accessories



**C066**  
Bar hook  
for 61 cm. truss



**FL105059HS**  
HL 105 cm. gate  
cm 59 truss-  
hoist support



**FL105047HSV**  
HL 105 cm. gate  
cm 47 truss-  
hoist support



**FL105MSZ1**  
Hoist support



**FL105ST**  
FL105 transport trolley  
system for 20 pieces



**FL105MS**  
Hoist support



**RA / Reinforcement arm**  
RA050 – working length 73 cm  
RA100 – working length 123 cm  
RA200 – working length 223 cm  
RA300 – working length 323 cm



**RAF / Reinforced tube w/forks**  
RAF047 – working length 47 cm  
RAF086 – working length 86 cm  
RAF100 – working length 100 cm  
RAF186 – working length 186 cm  
RAF200 – working length 200 cm



**RAH / Diagonal brace w/hooks**  
RAH014M2P – working length 14.2 cm  
RAH100M3P – working length 100 cm  
RAH141M4 – working length 141 cm  
RAH223M6 – working length 223 cm  
RAH282M8 – working length 282 cm



**RAL / 4 mm Aluminium pipe**  
RAL047 – length 47 cm  
RAL086 – length 86 cm  
RAL100 – length 100 cm  
RAL186 – length 186 cm  
RAL200 – length 200 cm  
RAL400 – length 400 cm

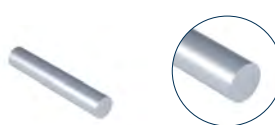

**RAT / Aluminium pipe w/caps**  
RAT050 – working length 50 cm  
RAT100 – working length 100 cm  
RAT150 – working length 150 cm  
RAT200 – working length 200 cm  
RAT250 – working length 250 cm  
RAT300 – working length 300 cm

## Frames

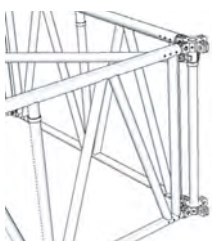

1



2

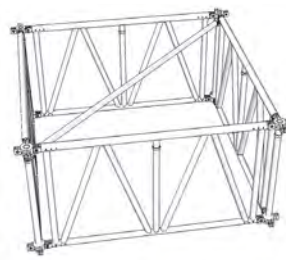

3

1 / Connection detail RAH FL105

2 / FL105 Connection

3 / FL105 Module









# FORK

## High Load Trusses

### **Load carrying capacity**

---

Load bearing trusses with universal fork connections for high-end solutions and excellent performances. Their design and twist-resistant geometry make High Load trusses usable both with horizontal and vertical forks.

They are strong and sturdy, and may be used as structural components in a grid, large load bearing beams or support towers. Some of the trusses in this line are built of extruded tubes with built in guides for inserting roofing sheets. Perfectly in line with international standard dimensions, they are totally integrated with the LIBERA System.

# RF40



High Load 40 x 29 cm rectangular-section aluminium truss. It is the most compact truss of the High Load series with a fork connection. Suitable for quite long spans, it keeps an optimum ratio between maximum load and truss deflection. The horizontally-aligned fork ends allow the truss to be used with only minimal accessories to build grid structures.

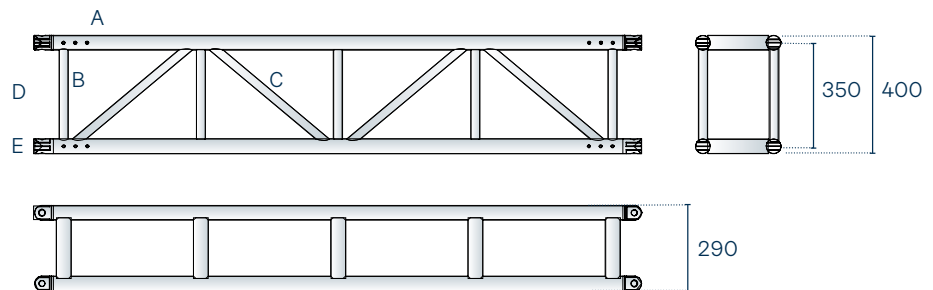

Chords A  
Extruded tube  $\varnothing$  50 x 3 mm  
EN AW-6082 T6

Diagonals B  
Extruded tube  $\varnothing$  30 x 3 mm  
EN AW-6082 T6

Braces C  
Extruded tube  $\varnothing$  30 x 3 mm  
EN AW-6082 T6

Braces D  
extruded tube  $\varnothing$  50 x 3 mm  
EN AW-6082 T6

Ends E  
Aluminium fork connector  
EN AW-6082 T6

Connection systems  
KHLP: cylindrical pin +  
safety R-clip

## Linear elements

code	cm	kg
RF40100	40 x 29 x 100	13.2
RF40200	40 x 29 x 200	16.8
RF40300	40 x 29 x 300	20.0
RF40400	40 x 29 x 400	23.2



### Load table / Spigot connection

SPAN	Unif. distributed load			Centre point load			Third point load			Quarter point load			Fifth point load		
	Point load	Full load	Central deflection	Point load	Full load	Central deflection	Point load	Full load	Central deflection	Point load	Full load	Central deflection	Point load	Full load	Central deflection
m	kg/m	kg	mm	kg	kg	mm	kg	kg	mm	kg	kg	mm	kg	kg	mm
3	1928	5785	5	2524	2524	4	1593	3186	4	1222	3665	4	1009	4038	5
4	1257	5029	11	2084	2084	7	1351	2702	8	1059	3176	9	887	3549	9
5	852	4262	18	1770	1770	12	1171	2343	14	932	2797	15	771	3084	16
6	616	3696	28	1537	1537	18	1032	2065	21	832	2496	24	666	2662	24
7	458	3205	38	1356	1356	26	920	1840	30	750	2250	34	585	2340	34
8	353	2822	50	1211	1211	35	830	1659	41	667	2000	45	519	2077	45
9	279	2515	64	1090	1090	45	754	1508	53	595	1786	58	467	1867	58
10	226	2264	80	990	990	57	690	1380	67	537	1610	73	423	1692	73
11	187	2054	98	905	905	70	634	1269	83	487	1462	88	386	1543	89
12	156	1875	117	832	832	85	586	1172	101	445	1336	106	354	1416	107
13	132	1721	138	768	768	101	544	1088	120	409	1227	125	326	1305	127
14	113	1586	160	711	711	119	505	1010	141	377	1131	146	302	1207	149
15	98	1467	185	660	660	138	471	942	164	349	1047	169	280	1120	172
16	85	1361	211	615	615	158	440	881	188	324	972	193	261	1042	197
17	74	1266	239	574	574	180	413	825	215	301	904	218	243	972	223
18	66	1180	268	536	536	204	387	774	243	281	843	246	227	908	252
19	58	1099	299	502	502	230	364	727	273	263	788	275	212	850	282
20	51	1026	331	471	471	257	342	684	305	245	736	306	199	796	314

### Cantilever load table / Fork connection

SPAN	Distributed load q			Point load F	
	Point load	Full load	Central deflection	Point load	Central deflection
m	kg/m	kg	mm	kg	mm
1	2165	2165	1	1593	1
2	790	1581	4	1035	7
3	413	1238	11	762	18
4	252	1010	22	598	34
5	169	846	36	488	55
6	120	722	55	408	81
7	89	624	77	348	111

### Axial load table

H m	kg
3	17392
6	8148
9	3852
12	2222
15	1407

Load table has been prepared in accordance with UNI ENV 1999-1-1 (Eurocode 9). When calculating the allowable loads it is assumed that the load is suspended from the bottom chord and the truss is supported from the top chord at each end. The values shown in the table are the allowable static loads that can be applied to the truss. This is the live load or the payload.

The self weight of the truss has been taken into account when calculating the values in the table. It should be noted that this are idealised loading conditions and the User shall re-analyze the truss for the loading conditions which prevail for the application being considered.

High Load structures can be extended using specially designed accessories for suspension, transportation and reinforcement, including hooks, corner frames and skates. Only forked connectors with steel junction pins are used. Designed to withstand the highest stress and load levels, they offer guaranteed compatibility with the whole series. Gates are short, flat section High Load elements generally used when putting together corners or tower sleeve blocks. Code numbers shown under the pictures refer to the shape and make it easy to identify.

## Connections



**KHLB**  
M20 screw bolt  
+ spring washer



**KHLD**  
M20 screw nut  
+ spring washer



**KHLF**  
Female fork connector  
complete



**KHLG**  
M20 Lifting Eye



**KHLM**  
Male fork  
connector complete



**KHL P**  
Cylindrical pin  
+ 3 mm safety R-clip



**KHL180A**  
180° double fork aluminum  
connector



**KHL180S**  
180° double fork  
steel connector



**KHL90LA**  
90° double fork  
alum. connector, left



**KHL90LS**  
90° double fork steel  
connector, left



**KHL90RA**  
90° double fork alum.  
connector, right



**KHL90RS**  
90° double fork steel  
connector, right



**KCFS**  
Kit for vert. connec incl.  
bolts, spigots and accessories



**TZHL01**  
FL assembly kit

## Accessories



**KF30L2135**  
Kit for 135° corner



**CBQ3040**  
4 points Bridle Hook for  
29/40 cm truss



**CS029-40**  
Ceiling support for 30-40  
series - silver

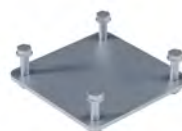

**KF30P3030**  
Plate for 90° corner incl.  
Bolts



**FF40023M9P**  
Heavy Load 40  
Gate - 23.9 cm



**C030**  
Bar hook for 29 cm. truss

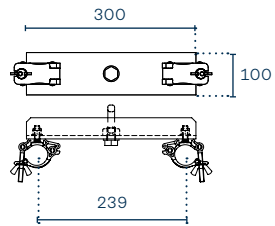

**CBT3040**  
2 points Bridle Hook for 29/40 cm. truss

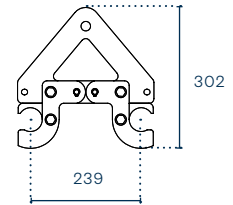

## Corner solutions

### A Corner 90°

KF30P3030

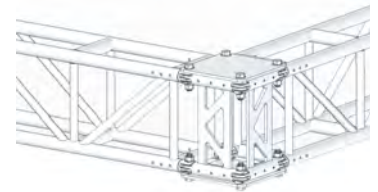
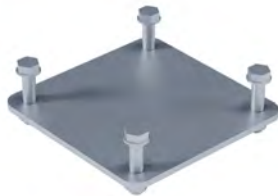

### B Corner 120°

FF40023M9P

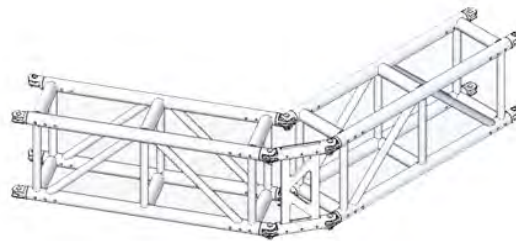

### C Corner 135°

KF30L2135

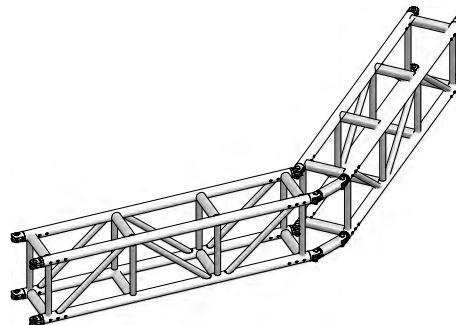

# QL40A

Anti-torsion

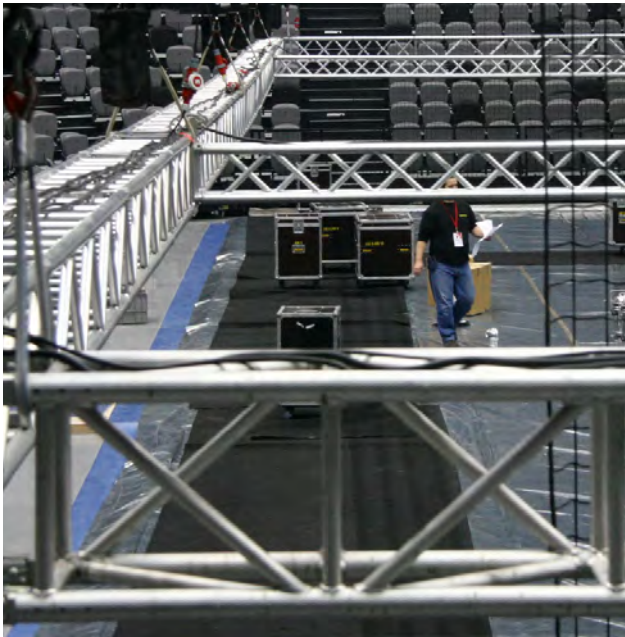

Square section High Load aluminium truss with 40 cm long sides. It is diagonalized on all faces and is provided with an aluminium fork connection. This guarantees excellent rigidity and elevated resistance in both horizontal and vertical applications despite its reduced section.

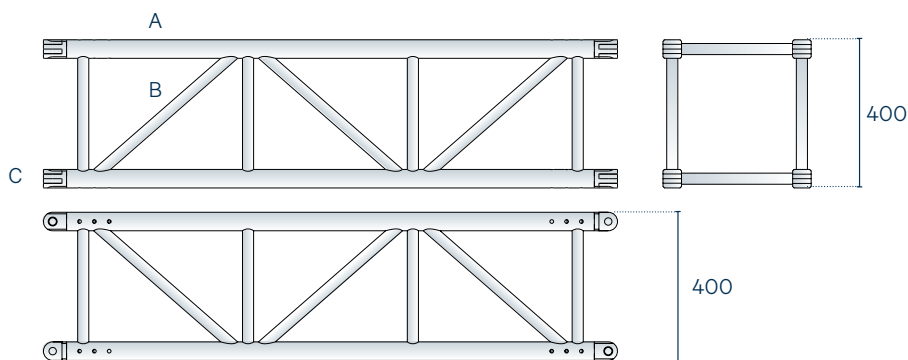

Chords A  
Extruded tube  $\varnothing$  50 x 4 mm  
EN AW-6082 T6

Diagonals B  
Extruded tube  $\varnothing$  30 x 3 mm  
EN AW-6082 T6

Ends C  
Aluminium forks connector  
EN AW-6082 T6

Connection systems  
KHLP: cylindrical pin +  
safety R-clip

## Gates and accessories

code	cm	kg
FL40035P	40 x 35 x 5	3.5
FL40049MS	40 x 49 x - 5 x 5	17.50
MTC30F	48 x 48 x 1	5
MTC30G / MTC30D	48 x 48 x 1	4.2
KHLP	40 x 40 x 300	36.20

## Linear elements

code	cm	kg
QL40100A	40 x 40 x 100	14.70
QL40130A	40 x 40 x 130	17.50
QL40200A	40 x 40 x 200	25.30
QL40300A	40 x 40 x 300	36.20





### Load table / Fork connection



SPAN	Unif. distributed load			Centre point load			Third point load			Quarter point load			Fifth point load		
	Point load	Full load	Central deflection	Point load	Full load	Central deflection	Point load	Full load	Central deflection	Point load	Full load	Central deflection	Point load	Full load	Central deflection
m	kg/m	kg	mm	kg	kg	mm	kg	kg	mm	kg	kg	mm	kg	kg	mm
3	1673	5018	3	3238	3238	4	2080	4161	4	1624	4871	4	1255	5018	4
4	1252	5007	8	2643	2643	7	1742	3484	8	1383	4149	9	1154	4615	9
5	999	4995	16	2230	2230	12	1497	2993	13	1206	3618	15	966	3862	15
6	742	4454	25	1926	1926	17	1310	2620	20	1068	3203	23	830	3320	23
7	542	3796	34	1692	1692	25	1163	2326	29	930	2789	32	726	2904	32
8	412	3300	45	1505	1505	33	1044	2088	39	819	2457	42	644	2576	42
9	323	2911	56	1353	1353	42	945	1889	50	728	2183	54	578	2310	54
10	260	2598	70	1227	1227	53	862	1724	63	650	1949	66	522	2087	68
11	213	2340	84	1119	1119	66	791	1582	78	585	1755	80	475	1902	83
12	177	2122	101	1027	1027	79	729	1459	95	531	1592	96	436	1742	100
13	149	1937	118	946	946	94	675	1350	113	484	1453	113	401	1604	118
14	127	1776	137	875	875	111	627	1254	133	444	1332	131	370	1480	138
15	109	1635	158	812	812	129	584	1169	154	409	1226	151	341	1363	159
16	94	1510	180	755	755	148	546	1091	177	378	1133	172	315	1259	181
17	82	1399	203	700	700	168	511	1021	202	350	1049	194	291	1166	205
18	72	1299	228	649	649	189	478	956	229	325	974	218	271	1082	230
19	64	1208	255	604	604	212	449	897	257	302	906	244	252	1006	256
20	56	1125	283	562	562	237	422	843	288	281	844	271	234	937	284

### Cantilever load table / Fork connection

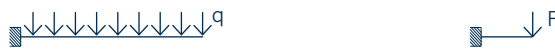

SPAN	Distributed load q			Point load F		
	Point load	Full load	Central deflection	Point load	Full load	Central deflection
m	kg/m	kg	mm	kg	kg	mm
0.5	5042	2521	0	2521	2521	0
1.0	2515	2515	1	2081	2081	1
1.5	1619	2429	2	1613	1613	4
2.0	1033	2066	4	1315	1315	7
2.5	720	1799	7	1108	1108	11
3.0	530	1590	11	955	955	17
3.5	406	1422	15	838	838	24
4.0	321	1284	21	745	745	32

### Axial load table



SPAN	Axial load F <sub>am</sub>	
	F <sub>am</sub>	F <sub>am</sub>
m	kg	kg
2	18054	17392
4	16913	9701
6	14903	5359
8	12244	
10	9631	
12	7507	
14	5898	
16	4696	

Load table has been prepared in accordance with UNI ENV 1999-1-1 (Eurocode 9). When calculating the allowable loads it is assumed that the load is suspended from the bottom chord and the truss is supported from the top chord at each end. The values shown in the table are the allowable static loads that can be applied to the truss. This is the live load or the payload.

The self weight of the truss has been taken into account when calculating the values in the table. It should be noted that this are idealised loading conditions and the User shall re-analyze the truss for the loading conditions which prevail for the application being considered.

High Load structures can be extended using specially designed accessories for suspension, transportation and reinforcement, including hooks, corner frames and skates. Only forked connectors with steel junction pins are used.

Designed to withstand the highest stress and load levels, they offer guaranteed compatibility with the whole series.

Gates are short, flat section High Load elements generally used when putting together corners or tower sleeve blocks. Code numbers shown under the pictures refer to the shape and make it easy to identify.

## Connections



**KHLB**  
M20 screw bolt  
+ spring washer

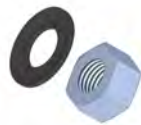

**KHLD**  
M20 screw nut  
+ spring washer



**KHLF**  
Female fork connector  
complete



**KHLG**  
M20 Lifting Eye



**KMLM**  
Male fork  
connector complete



**KHLP**  
Cylindrical pin  
+ 3 mm safety R-clip



**KHL180A**  
180° double fork aluminum  
connector



**KHL180S**  
180° double fork  
steel connector



**KHL90LA**  
90° double fork  
alum. connector, left



**KHL90LS**  
90° double fork steel  
connector, left



**KHL90RA**  
90° double fork alum.  
connector, right



**KHL90RS**  
90° double fork steel  
connector, right



**TZHL01**  
FL assembly kit

## Accessories



**C040**  
Bar hook for 40 cm. truss



**FP40Z1**  
Universal 40 cm truss floor  
plate



**MTC30F**  
Square frame with bolts  
for QF40



**QL40X4C - HL40**  
4 ways compact corner



**QL40X6C - HL4**  
6 ways compact corner



**MTC30D - MT30**  
lower frame w/wheels



**MTC30G - MT30**  
upper frame w/wheels  
& eye bolts

## Gates



**FL40035P**  
HL 40 cm.  
flat - 35 cm



**FL40049M5P**  
HL 40 cm.  
flat - 49.5 cm



**FL40047HS**  
HL40 cm flat - 47 cm gate  
w/hoist support



**FL40047PH**  
HL40 cm flat - 47 cm gate  
w/forks

## Corner solutions

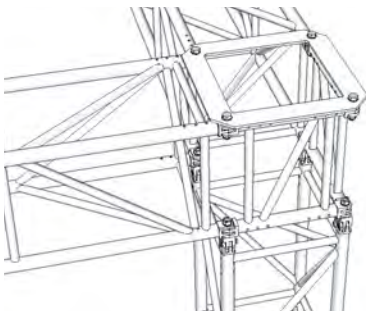

1

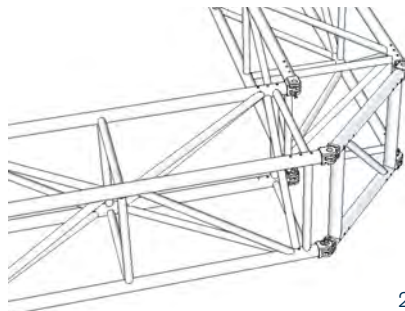

2

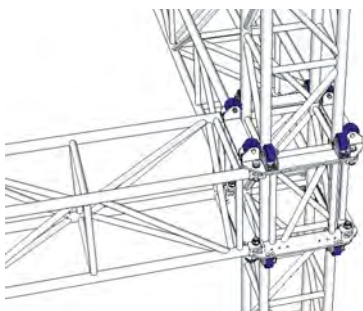

3

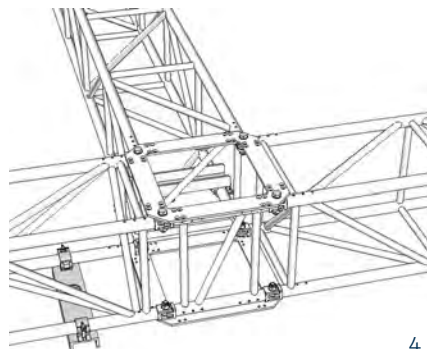

4

1 / 90° solution with pillar

2 / 90° solution with gate

3 / 90° solution with wheeled frame

4 / 3-way solution with frame

# QL52A

Anti-torsion



Square section High Load aluminium truss with 52 cm long sides. It is diagonalized on all faces and is provided with an aluminium fork connection. It shows great versatility in use both as a tower (Maxitower 52) and as a span.

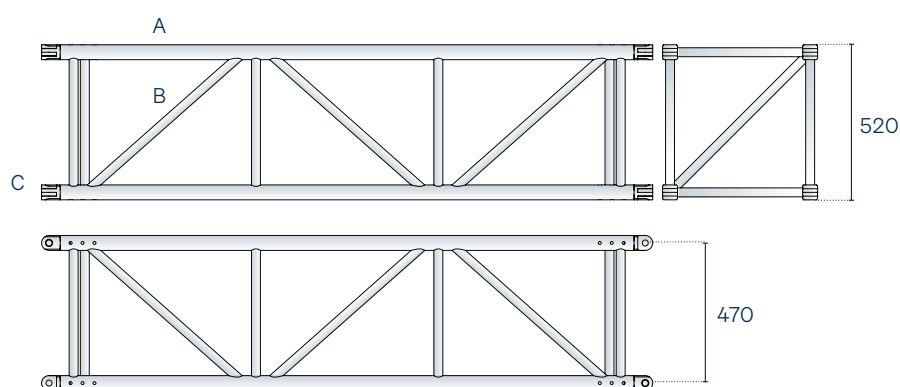

Chords A  
Extruded tube  $\varnothing$  50 x 4 mm  
EN AW-6082 T6

Diagonals B  
Extruded tube  $\varnothing$  30 x 3 mm  
EN AW-6082 T6

Ends C  
Aluminium forks connector  
EN AW-W6082 T6

Connection systems  
KHLP: cylindrical pin +  
safety R-clip

## Gates and accessories

code	cm	kg
QL52050A	52 x 52 x 50	12.30
QL52100A	52 x 52 x 100	16.70
QL52130A	52 x 52 x 130	19.20
QL52200A	52 x 52 x 200	26.70
QL52250A	52 x 52 x 250	34.00
QL52300A	52 x 52 x 300	36.60

## Linear elements

code	cm	kg
FL52047P	52 x 47 x 5	4.4
FL52059P	52 x 59 x 5	4.7
FL52066MSP	52 x 66.5 x 5	5.0
MTC40F	59 x 59 x 1	4.3
MTC40G / MTC40D	59 x 59 x 1	14.5 / 13.3
KHLP	$\varnothing$ 2	0.15

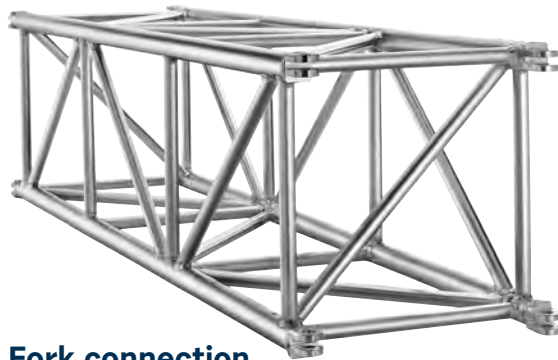

### Load table / Fork connection

SPAN	Unif. distributed load			Centre point load			Third point load			Quarter point load			Fifth point load		
	Point load	Full load	Central deflection	Point load	Full load	Central deflection	Point load	Full load	Central deflection	Point load	Full load	Central deflection	Point load	Full load	Central deflection
m	kg/m	kg	mm	kg	kg	mm	kg	kg	mm	kg	kg	mm	kg	kg	mm
3	1432	4296	2	3905	3905	2	2148	4296	2	1432	4296	2	1074	4296	2
4	1071	4285	4	3248	3248	5	2087	4174	5	1428	4285	5	1071	4285	5
5	855	4273	8	2779	2779	8	1820	3641	9	1424	4273	10	1068	4273	9
6	710	4262	13	2426	2426	12	1613	3226	14	1291	3872	15	1055	4219	16
7	607	4250	21	2150	2150	17	1447	2893	20	1169	3507	22	930	3721	22
8	523	4186	31	1927	1927	23	1310	2620	27	1046	3139	30	831	3323	30
9	386	3473	37	1736	1736	30	1196	2391	35	868	2605	35	723	2894	37
10	312	3124	46	1562	1562	37	1098	2196	44	781	2343	44	651	2603	47
11	256	2815	56	1407	1407	45	1014	2028	55	704	2111	53	586	2346	56
12	213	2554	67	1277	1277	54	941	1881	67	638	1915	63	532	2128	67
13	179	2333	78	1166	1166	64	875	1749	80	583	1749	74	486	1944	79
14	153	2139	90	1069	1069	74	802	1604	92	535	1604	86	446	1782	91
15	131	1969	104	984	984	85	738	1476	106	492	1476	99	410	1640	105
16	114	1818	118	909	909	97	682	1364	120	455	1364	113	379	1515	119
17	99	1684	133	842	842	109	631	1263	136	421	1263	127	351	1403	134
18	87	1563	149	781	781	123	586	1172	152	391	1172	142	326	1302	150
19	76	1453	166	727	727	137	545	1090	169	363	1090	159	303	1211	167
20	68	1354	183	677	677	153	508	1015	187	338	1015	176	282	1128	185
21	60	1262	202	631	631	169	473	946	206	315	946	194	263	1052	203
22	54	1178	221	589	589	186	442	883	225	294	883	212	245	981	223

### Cantilever load table / Fork connection

SPAN	Unif. distributed load			Centre point load		
	Point load	Full load	Central deflection	Point load	Full load	Central deflection
m	kg/m	kg	mm	kg	mm	
0.5	4319	2160	0	2160	2160	0
1.0	2154	2154	0	2154	2154	1
1.5	1432	2148	1	1947	1947	2
2.0	1071	2142	2	1617	1617	5
2.5	855	2137	5	1381	1381	8
3.0	641	1924	7	1204	1204	12
3.5	497	1740	10	1066	1066	17
4.0	396	1586	14	954	954	23

### Axial load table

SPAN	Axial load	
	F <sub>am.</sub>	F <sub>am.</sub>
m	kg	kg
3	17713	15145
5	16850	10342
10	12720	
12	10729	
14	8930	
16	7418	
18	6186	
20	5191	

Load table has been prepared in accordance with UNI ENV 1999-1-1 (Eurocode 9). When calculating the allowable loads it is assumed that the load is suspended from the bottom chord and the truss is supported from the top chord at each end. The values shown in the table are the allowable static loads that can be applied to the truss. This is the live load or the payload.

The self weight of the truss has been taken into account when calculating the values in the table. It should be noted that this are idealised loading conditions and the User shall re-analyze the truss for the loading conditions which prevail for the application being considered.

High Load structures can be extended using specially designed accessories for suspension, transportation and reinforcement, including hooks, corner frames and skates. Only forked connectors with steel junction pins are used. Designed to withstand the highest stress and load levels, they offer guaranteed compatibility with the whole series.

Gates are short, flat section High Load elements generally used when putting together corners or tower sleeve blocks. Code numbers shown under the pictures refer to the shape and make it easy to identify.

## Connections



**KHLB**  
M20 screw bolt  
+ spring washer

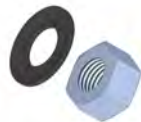

**KHLD**  
M20 screw nut  
+ spring washer



**KHLF**  
Female fork connector  
complete



**KHLG**  
M20 Lifting Eye



**KHLM**  
Male fork  
connector complete



**KHLP**  
Cylindrical pin  
+ 3 mm safety R-clip



**KHL180A**  
180° double fork aluminum  
connector



**KHL180S**  
180° double fork  
steel connector



**KHL90LA**  
90° double fork  
alum. connector, left



**KHL90LS**  
90° double fork steel  
connector, left



**KHL90RA**  
90° double fork alum.  
connector, right



**KHL90RS**  
90° double fork steel  
connector, right



**TZHL01**  
FL assembly kit

## Accessories



**QL52X6C**  
HL 52 - 6 ways  
compact corner



**C052D**  
Bar hook for 52 cm truss



**FP52Z1**  
Universal 52 cm truss floor  
plate



**MTC40D**  
Lower frame MT40,  
w/ wheels



**MTC40F**  
Square frame with bolts



**MTC40G**  
Upper frame MT40,  
w/ wheels and eye bolts



**FL52047HS**  
HL 52 cm gate - cm 47  
truss - hoist support



**FL52047HSZ1**  
Hoist support

## Gates



**FL52047P**  
HL 52 cm.  
flat - 47 cm



**FL52066M5P**  
HL 52 cm.  
flat - 66.5 cm



**FL52047HS**  
HL52 cm flat - 47 cm gate  
w/hoist support



**FL52059PH**  
HL52 cm flat - 59 cm gate  
w/forks

## Corner solutions

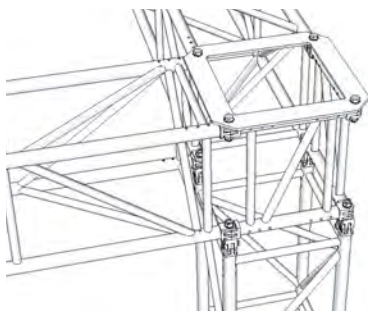

1

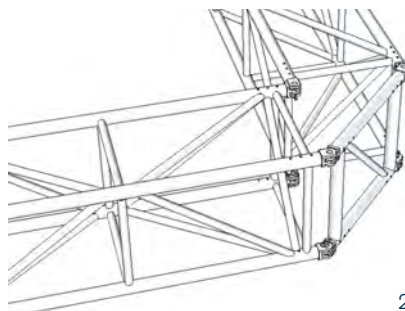

2

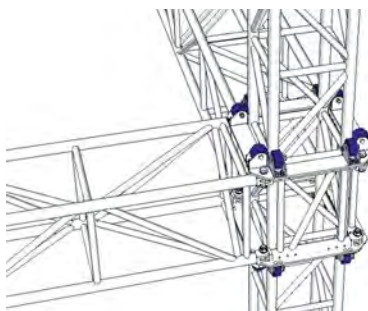

3

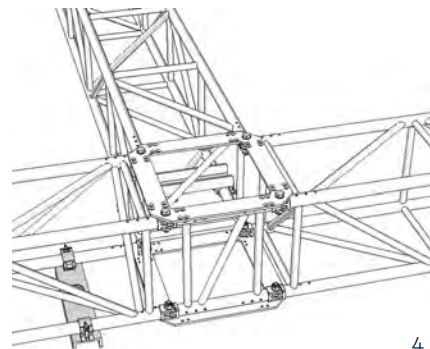

4

- 1 / 90° solution with pillar
- 2 / 90° solution with gate
- 3 / 90° solution with wheeled frame
- 4 / 3-way solution with frame

# QL76A

## Anti-torsion



Square section High Load aluminium truss with 76 cm long sides. It is provided with steel fork connections and  $\varnothing 50 \times 4$  mm chords. Thanks to its elevated moment of inertia and resistance of its connections, it is mainly used in the composition of towers (Maxitower 76).

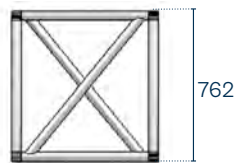
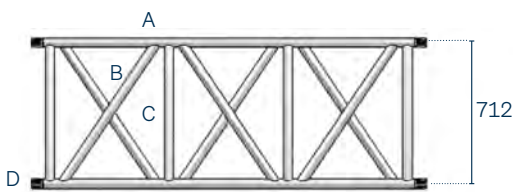

### Linear elements

code	cm	kg
QL76078A Type A	76.2 x 76.2 x 78	30.70
QL76078AB Type B	76.2 x 76.2 x 78	30.70
QL76200A Type A	76.2 x 76.2 x 200	56.70
QL76200AB ype B	76.2 x 76.2 x 200	56.70
QL76250A Type A	76.2 x 76.2 x 250	68.60

#### Chords A

Extruded tube  $\varnothing 50 \times 4$  mm  
EN AW-6082 T6

#### Diagonals B

Extruded tube  $\varnothing 50 \times 3$  mm  
EN AW-6082 T6

#### Braces C

Wxtruded tube  $\varnothing 50 \times 4$  mm  
EN AW-6082 T6

#### Ends C

Steel forks connector  
11SMnPb37

#### Connection systems

KHLP: cylindrical pin +  
safety R-clip

### Cantilever load table / Fork connection



SPAN m	Point load		Full load	Central deflection	Point load	
	kg/m	kg	kg	mm	kg	mm
0.5	5808	2904	2904	0	2904	0
1.0	2891	2891	2891	0	2891	0
1.5	1919	2878	2878	1	2733	1
2.0	1433	2866	2866	1	2263	3
2.5	1141	2853	2853	3	1927	5
3.0	894	2682	2682	4	1675	7
3.5	691	2417	2417	6	1477	10
4.0	549	2194	2194	9	1317	14
4.5	445	2004	2004	12	1186	18
5.0	368	1840	1840	15	1075	22
5.5	308	1696	1696	18	980	28
6.0	261	1569	1569	22	898	33



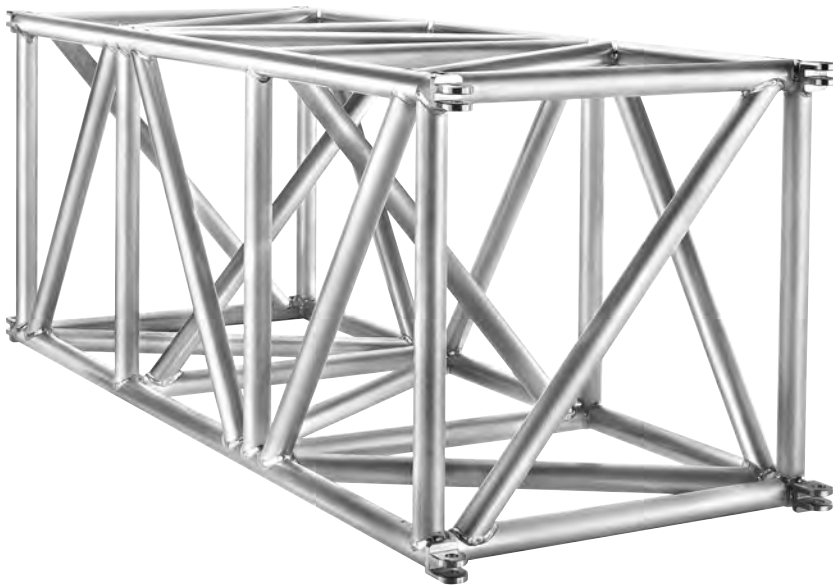

### Axial load table

SPAN		
	F <sub>am</sub>	F <sub>am</sub>
m	kg	kg
5	16788	13954
10	15087	6692
15	12178	
20	8914	
25	6307	

### Load table / Fork connection

SPAN															
	Point load	Full load	Central deflection	Point load	Full load	Central deflection	Point load	Full load	Central deflection	Point load	Full load	Central deflection	Point load	Full load	Central deflection
m	kg/m	kg	mm	kg	kg	mm	kg	kg	mm	kg	kg	mm	kg	kg	mm
5	1141	5705	5	3891	3891	5	2201	4401	5	1701	5104	5	1414	5654	5
6	947	5680	8	3388	3388	8	1972	3945	7	1544	4631	8	1295	5179	9
7	808	5654	12	2994	2994	11	1782	3565	11	1411	4233	12	1193	4771	13
8	704	5628	19	2677	2677	14	1625	3250	15	1298	3894	16	1070	4281	17
9	563	5065	24	2414	2414	19	1490	2981	20	1200	3599	22	968	3870	22
10	451	4506	30	2194	2194	24	1374	2747	25	1112	3337	28	881	3526	28
11	368	4048	36	2005	2005	29	1271	2542	31	1012	3036	34	807	3230	35
12	305	3662	43	1831	1831	35	1180	2360	38	916	2747	41	743	2972	42
13	256	3330	51	1665	1665	41	1099	2197	46	832	2497	48	686	2745	50
14	217	3041	59	1521	1521	48	1025	2050	54	760	2281	56	634	2535	59
15	186	2789	67	1395	1395	56	958	1917	64	697	2092	65	581	2324	68
16	160	2565	77	1283	1283	64	897	1795	74	641	1924	74	534	2138	77
17	139	2364	87	1182	1182	73	841	1683	85	591	1773	83	492	1970	88
18	121	2182	98	1091	1091	82	789	1578	97	546	1637	94	455	1819	98
19	106	2017	109	1009	1009	92	741	1482	109	504	1513	105	420	1681	110
20	93	1866	121	933	933	103	696	1392	123	467	1400	117	389	1555	122
21	82	1727	134	864	864	114	648	1295	136	432	1295	129	360	1439	135
22	73	1598	147	799	799	126	599	1199	150	400	1199	142	333	1332	148
23	64	1479	161	739	739	139	554	1109	164	370	1109	156	308	1232	162
24	57	1367	176	683	683	153	512	1025	179	342	1025	170	285	1139	177
25	50	1261	192	631	631	167	473	946	194	315	946	186	263	1051	193
26	45	1162	208	581	581	183	436	872	211	291	872	202	242	969	209
27	40	1069	225	534	534	199	401	802	228	267	802	218	223	891	226
28	35	980	243	490	490	216	368	735	246	245	735	236	204	817	244
29	31	896	261	448	448	234	336	672	264	224	672	254	187	747	262
30	27	815	280	408	408	253	306	612	284	204	612	274	170	680	282

Load table has been prepared in accordance with UNI ENV 1999-1-1 (Eurocode 9). When calculating the allowable loads it is assumed that the load is suspended from the bottom chord and the truss is supported from the top chord at each end.  
The values shown in the table are the allowable static loads that can be applied to the truss. This is the live load or the payload.

The self weight of the truss has been taken into account when calculating the values in the table.  
It should be noted that this are idealised loading conditions and the User shall re-analyze the truss for the loading conditions which prevail for the application being considered.

High Load structures can be extended using specially designed accessories for suspension, transportation and reinforcement, including hooks, corner frames and skates. Only forked connectors with steel junction pins are used. Designed to withstand the highest stress and load levels, they offer guaranteed compatibility with the whole series.

Gates are short, flat section High Load elements generally used when putting together corners or tower sleeve blocks. Code numbers shown under the pictures refer to the shape and make it easy to identify.

## Connections



**KHLB**  
M20 screw bolt  
+ spring washer



**KHLD**  
M20 screw nut  
+ spring washer



**KHLF**  
Female fork connector  
complete



**KHLG**  
M20 Lifting Eye



**KHLM**  
Male fork  
connector complete



**KHL P**  
Cylindrical pin  
+ 3 mm safety R-clip



**KHL180A**  
180° double fork aluminum  
connector



**KHL180S**  
180° double fork  
steel connector



**KHL90LA**  
90° double fork  
alum. connector, left



**KHL90LS**  
90° double fork steel  
connector, left



**KHL90RA**  
90° double fork alum.  
connector, right



**KHL90RS**  
90° double fork steel  
connector, right



**TZHL01**  
FL assembly kit

## Accessories



**MTC76F**  
MT76 frame with bolts



**MTC76D**  
MT76 frame with wheels



**FL76071M2HS**  
FL76 cm 71.2  
+ motor support



**FL76071M2P**  
Gate - HL76 Flat truss  
L = 71.2 cm

## Towers

QL76200A e AB

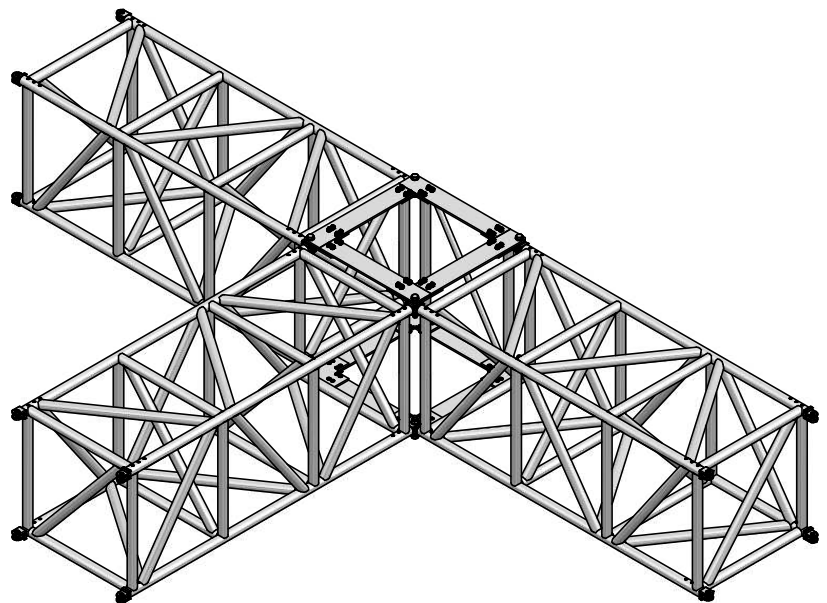
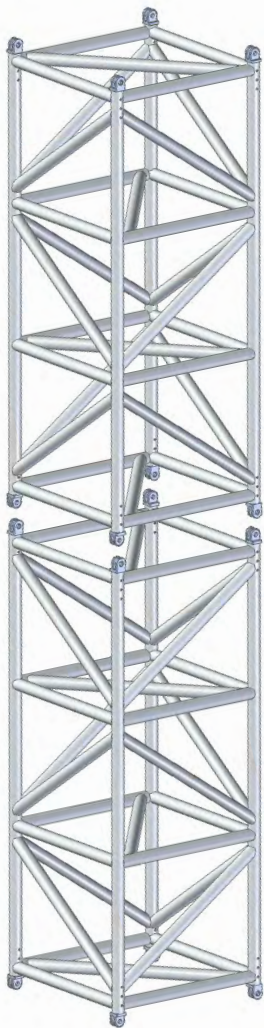

# QL85A

## Anti-torsion

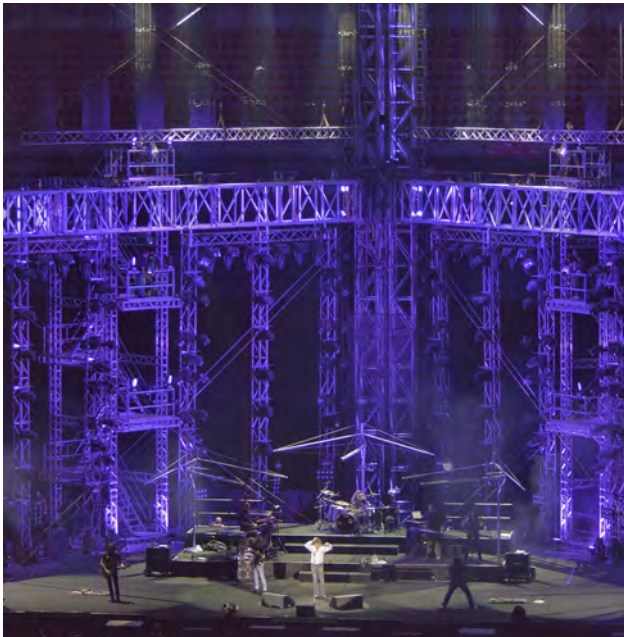

Square section High Load aluminium truss with 85 cm long sides. It is provided with steel fork connections and  $\varnothing 70 \times 5$  mm chords. Thanks to its elevated moment of inertia and resistance of its connections, it is mainly used in the composition of towers. in the composition of towers.

### Linear elements

code	cm	kg
QL85200A	85 x 85 x 200	83.6
QL85300A	85 x 85 x 300	107.2
QL85300AB	85 x 85 x 300	107.2

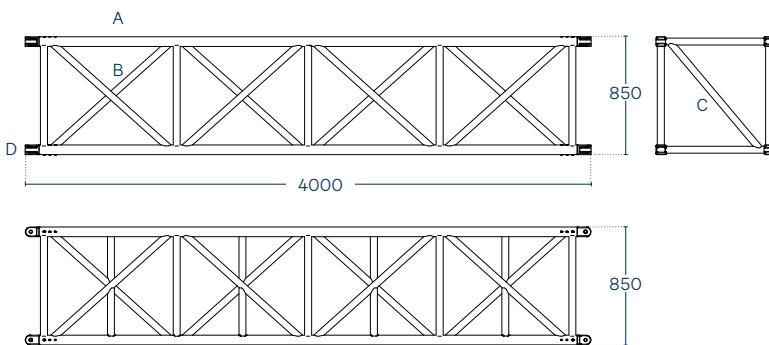

### Chords A

Extruded tube  $\varnothing 70 \times 5$  mm  
EN AW-6082 T6

### Diagonals B

Extruded tube  $\varnothing 50 \times 4$  mm  
EN AW-6082 T6

### Braces C

Extruded tube  $\varnothing 50 \times 4$  mm  
EN AW-6082 T6

### Ends C

Steel forks connector  
EN AW-6082 T6

### Connection systems

KHLP24L97: cylindrical pin +  
safety R-clip

### Cantilever load table / Fork connection



SPAN m	Point load		Full load kg	Central deflection mm	Point load	
	kg/m	kg			kg	Central deflection mm
0.5	5494	2747	0	2747	0	
1.0	2730	2730	0	2730	0	
1.5	1809	2714	0	2714	1	
2.0	1349	2697	1	2697	2	
2.5	1072	2681	1	2681	3	
3.0	888	2664	2	2664	5	
3.5	757	2648	3	2496	8	
4.0	658	2631	5	2289	11	
4.5	581	2615	7	2111	15	
5.0	520	2598	10	1936	19	
5.5	469	2582	13	1744	23	
6.0	428	2565	17	1583	27	

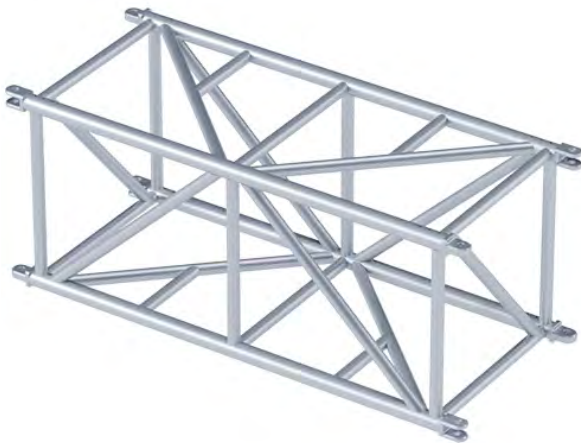

### Axial load table

SPAN	F <sub>am.</sub>		SPAN	F <sub>am.</sub>	
	kg	kg		kg	kg
m	kg	kg	m	kg	kg
10	24548	12417	20	15842	
12	23038	9508	22	14165	
14	21323	7358	24	12631	
16	19490		26	11249	
18	17636				

### Load table / Fork connection

SPAN	Unif. distributed load			Centre point load			Third point load			Quarter point load			Fifth point load		
	Point load	Full load	Central deflection	Point load	Full load	Central deflection	Point load	Full load	Central deflection	Point load	Full load	Central deflection	Point load	Full load	Central deflection
	kg/m	kg	mm	kg	kg	mm	kg	kg	mm	kg	kg	mm	kg	kg	mm
5	1072	5362	2	5362	5362	3	2681	5362	3	1787	5362	3	1340	5362	2
6	888	5329	4	5329	5329	6	2664	5329	5	1776	5329	4	1332	5329	4
7	757	5296	6	5089	5089	8	2648	5296	8	1765	5296	7	1324	5296	7
8	658	5263	8	4681	4681	12	2631	5263	11	1754	5263	10	1316	5263	10
9	581	5230	12	4329	4329	15	2615	5230	16	1743	5230	15	1307	5230	14
10	520	5197	16	4021	4021	20	2565	5130	22	1732	5197	20	1299	5197	19
11	469	5164	22	3665	3665	24	2413	4826	27	1721	5164	27	1291	5164	26
12	428	5131	28	3366	3366	29	2275	4551	34	1683	5049	35	1283	5131	34
13	392	5098	36	3098	3098	35	2150	4301	41	1549	4647	41	1274	5098	43
14	362	5064	45	2867	2867	41	2036	4072	49	1433	4300	48	1194	4778	51
15	335	5031	55	2643	2643	47	1931	3862	57	1321	3964	55	1101	4405	58
16	306	4890	66	2445	2445	54	1834	3667	67	1222	3667	63	1019	4075	66
17	267	4537	74	2268	2268	61	1701	3403	76	1134	3403	71	945	3781	75
18	234	4219	83	2110	2110	69	1582	3165	85	1055	3165	80	879	3516	84
19	207	3932	93	1966	1966	77	1475	2949	95	983	2949	89	819	3277	94
20	184	3670	103	1835	1835	86	1376	2753	105	918	2753	99	765	3059	104
21	163	3430	114	1715	1715	95	1286	2573	116	858	2573	109	715	2859	115
22	146	3209	125	1605	1605	105	1203	2407	127	802	2407	120	669	2674	126
23	131	3004	137	1502	1502	116	1127	2253	139	751	2253	132	626	2504	138
24	117	2814	150	1407	1407	127	1055	2111	152	704	2111	144	586	2345	150
25	105	2636	163	1318	1318	138	989	1977	165	659	1977	157	549	2197	164
26	95	2470	176	1235	1235	151	926	1852	179	617	1852	170	515	2058	177
27	86	2313	190	1157	1157	164	867	1735	193	578	1735	184	482	1928	191
28	77	2165	205	1083	1083	177	812	1624	208	541	1624	198	451	1804	206
29	70	2025	221	1013	1013	192	759	1519	224	506	1519	213	422	1688	222
30	63	1893	237	946	946	207	710	1419	240	473	1419	229	394	1577	238

Load table has been prepared in accordance with UNI ENV 1999-1-1 (Eurocode 9). When calculating the allowable loads it is assumed that the load is suspended from the bottom chord and the truss is supported from the top chord at each end. The values shown in the table are the allowable static loads that can be applied to the truss. This is the live load or the payload.

The self weight of the truss has been taken into account when calculating the values in the table. It should be noted that this are idealised loading conditions and the User shall re-analyze the truss for the loading conditions which prevail for the application being considered.

# RL76A

## Anti-torsion



Rectangular section High Load aluminium truss with 76 x 52 cm long sides. It is diagonalized on all faces and is provided with steel fork connections. It ensures high load capacity on medium-long spans thanks to the design of its main components.

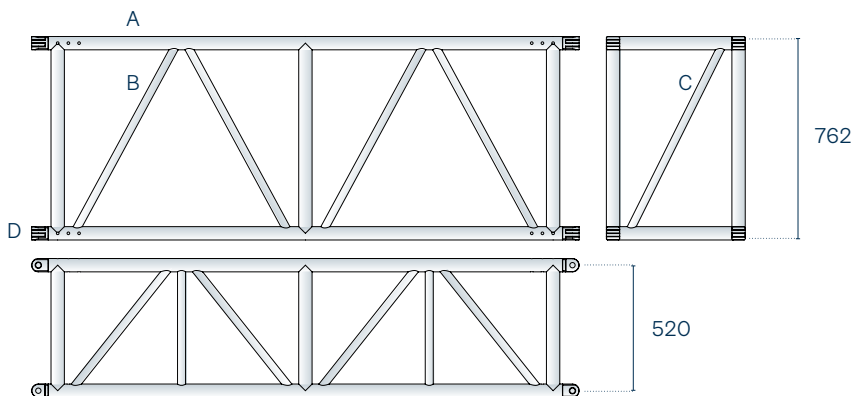

### Linear elements

code	cm	kg
RL76100A	76.2 x 52 x 100	19.40
RL76200A	76.2 x 52 x 200	45.00
RL76300A	76.2 x 52 x 300	52.00

### Corners and sleeve block

code	cm	kg
FL76047P	76.2 x 47 x 5	8.9
FL76066M5	76.2 x 66.5 x 5	9.7
MTC40F	59 x 59 x 1	4.3
MTC40G / MTC40D	59 x 59 x 1	13.3 / 14.5
KHLP	Ø2	0.15

#### Chords A

Extruded tube Ø 50 x 4 mm  
EN AW-6082 T6

#### Diagonals B

Extruded tube Ø 30 x 3 mm  
EN AW-6082 T6

#### Braces C

Extruded tube Ø 50 x 4 mm  
EN AW-6082 T6

#### Ends C

Steel forks connector  
11SMnPb37

#### Connection systems

KHLP: cylindrical pin + safety R-clip

### Cantilever load table / Fork connection



SPAN	Full load			Point load	
	kg/m	kg	Central deflection mm	kg	Central deflection mm
m					
1.0	2873	2873	0	2873	1
2.0	1428	2855	3	2305	7
3.0	917	2751	10	1707	17
4.0	564	2257	20	1348	32
5.0	380	1902	34	1106	52
6.0	272	1633	52	931	77

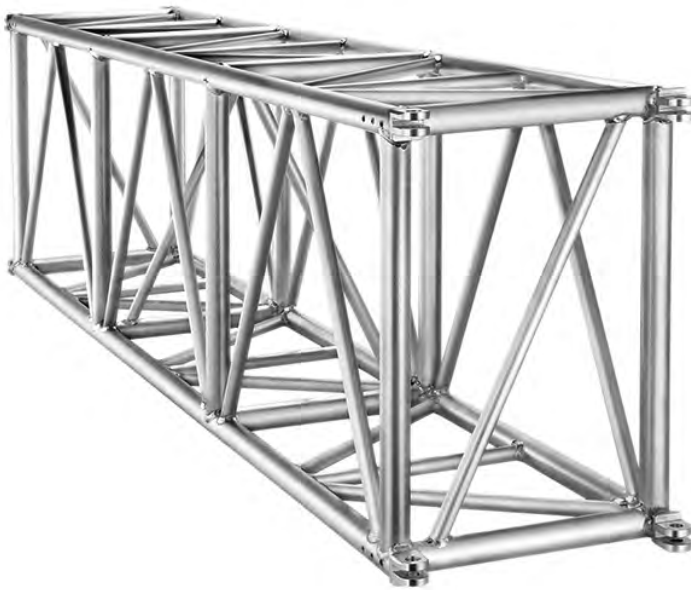

### Axial load table

SPAN		
	F <sub>am.</sub>	F <sub>am.</sub>
m	kg	kg
3	16542	14191
6	15175	7669
9	12818	
12	9984	
13	9093	
14	8266	
15	7508	
16	6821	
17	6202	
18	5645	

### Load table / Fork connection

SPAN															
	Unif. distributed load			Centre point load			Third point load			Quarter point load			Fifth point load		
	Point load	Full load	Central deflection	Point load	Full load	Central deflection	Point load	Full load	Central deflection	Point load	Full load	Central deflection	Point load	Full load	Central deflection
m	kg/m	kg	mm	kg	kg	mm	kg	kg	mm	kg	kg	mm	kg	kg	mm
3	1910	5729	2	5593	5593	3	2864	5729	3	1910	5729	3	1432	5729	3
4	1428	5711	5	4633	4633	7	2855	5711	7	1904	5711	7	1428	5711	6
5	1139	5693	10	3952	3952	11	2601	5202	13	1898	5693	13	1423	5693	12
6	946	5675	18	3441	3441	17	2299	4597	20	1846	5539	22	1419	5675	21
7	808	5657	28	3043	3043	24	2057	4114	28	1669	5006	32	1314	5258	32
8	705	5639	42	2724	2724	33	1859	3718	38	1492	4476	42	1172	4688	42
9	586	5271	57	2462	2462	43	1694	3387	50	1318	3953	54	1056	4224	55
10	471	4710	70	2242	2242	54	1553	3106	63	1177	3532	66	959	3836	69
11	386	4247	85	2054	2054	66	1432	2864	78	1062	3186	81	877	3508	84
12	322	3859	101	1892	1892	80	1326	2652	95	965	2894	96	804	3216	101
13	271	3528	118	1751	1751	96	1233	2466	113	882	2646	113	735	2940	119
14	232	3241	137	1621	1621	112	1150	2301	133	810	2431	131	675	2701	138
15	199	2991	158	1495	1495	129	1076	2152	155	748	2243	151	623	2492	159
16	173	2769	180	1384	1384	148	1009	2018	179	692	2077	172	577	2307	181
17	151	2571	203	1286	1286	167	948	1896	204	643	1928	194	536	2143	205
18	133	2394	228	1197	1197	189	892	1785	232	598	1795	218	499	1995	230
19	118	2233	255	1116	1116	211	837	1675	260	558	1675	244	465	1861	256
20	104	2086	283	1043	1043	235	782	1565	288	522	1565	271	435	1738	285
21	93	1952	312	976	976	261	732	1464	318	488	1464	299	407	1626	314
22	83	1828	343	914	914	288	686	1371	349	457	1371	329	381	1523	345
23	75	1714	376	857	857	316	643	1285	382	428	1285	361	357	1428	378
24	67	1607	410	804	804	347	603	1205	417	402	1205	394	335	1339	412
25	60	1508	446	754	754	379	565	1131	453	377	1131	429	314	1256	448

Load table has been prepared in accordance with UNI ENV 1999-1-1 (Eurocode 9). When calculating the allowable loads it is assumed that the load is suspended from the bottom chord and the truss is supported from the top chord at each end. The values shown in the table are the allowable static loads that can be applied to the truss. This is the live load or the payload.

The self weight of the truss has been taken into account when calculating the values in the table. It should be noted that this are idealised loading conditions and the User shall re-analyze the truss for the loading conditions which prevail for the application being considered.

High Load structures can be extended using specially designed accessories for suspension, transportation and reinforcement, including hooks, corner frames and skates. Only forked connectors with steel junction pins are used. Designed to withstand the highest stress and load levels, they offer guaranteed compatibility with the whole series.

Gates are short, flat section High Load elements generally used when putting together corners or tower sleeve blocks. Code numbers shown under the pictures refer to the shape and make it easy to identify.

## Connections



**KHLB**  
M20 screw bolt  
+ spring washer

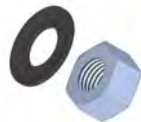

**KHLD**  
M20 screw nut  
+ spring washer



**KHLF**  
Female fork connector  
complete



**KHLG**  
M20 Lifting Eye



**KHLM**  
Male fork  
connector complete



**KHLP**  
Cylindrical pin  
+ 3 mm safety R-clip



**KHL180A**  
180° double fork aluminum  
connector



**KHL180S**  
180° double fork  
steel connector



**KHL90LA**  
90° double fork  
alum. connector, left



**KHL90LS**  
90° double fork steel  
connector, left



**KHL90RA**  
90° double fork alum.  
connector, right



**KHL90RS**  
90° double fork steel  
connector, right



**TZHL01**  
FL assembly kit

## Accessories



**C052D**  
Bar hook for 52 cm truss



**FP7652Z1**  
Universal 52 cm truss floor  
plate



**MTC40D**  
Lower frame MT40,  
w/ wheels



**MTC40F**  
Square frame with bolts



**MTC40G**  
Upper frame MT40,  
w/ wheels and rings





**MTC52D**  
Lower frame - QL52A truss,  
w/ wheels



**MTC52G**  
Upper frame - QL52A truss,  
w/ wheels and rings



**FL76047HS**  
HL 76 cm. gate - 47 cm  
truss - hoist support



**FL76047HSZ1**  
HL76 cm gate - 47 cm  
truss - hoist support

## Gates



**FL76047P**  
HL 76 cm ladder cm  
47 truss with horizontal forks



**FL76059P**  
HL 76 cm. gate - cm. 59  
truss w/ horizontal  
forks - FL76



**FL76059PH**  
HL 76 cm. gate - cm. 59  
truss w/ coupling - RL76/  
FL76



**FL76066M5P**  
HL 76 cm. ladder - cm.  
66.5 truss with  
horizontal forks

## Corner solutions



1

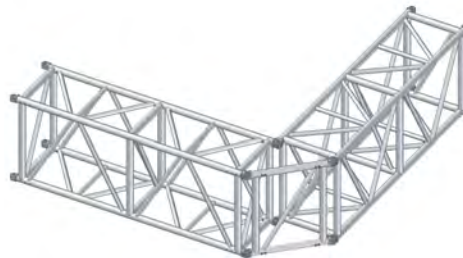

2

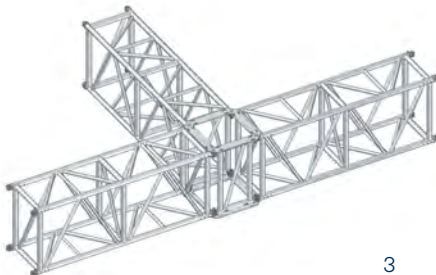

3

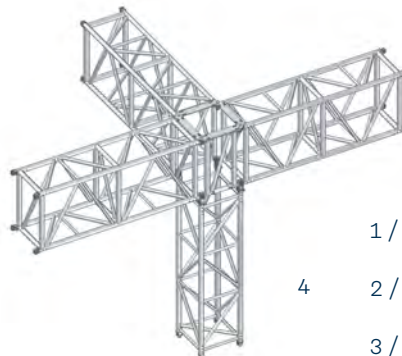

4

1 / 90° solution with frame

2 / 90° solution with gate

3 / 3-way solution with frame

4 / 4-way solution with frame

# RL105A

Anti-torsion



Rectangular section High Load aluminium truss with 105 x 67 cm long sides. It is intended for uses that require elevated loads on large spans. The steel fork connection bestows sturdiness and wear resistance to the system. It is designed and tested according to the most widespread international standards.

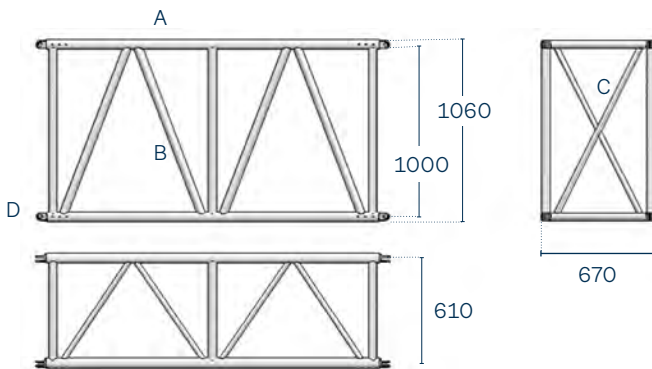

Chords A  
Extruded tube  $\varnothing$  60 x 5 mm  
EN AW 6082 T6

Diagonals B  
Extruded tube  $\varnothing$  50 x 3 mm  
EN AW 6082 T6

Braces C  
Extruded tube  $\varnothing$  50 x 4 mm  
EN AW 6082 T6

Ends D  
Steel forks connector  
11SMnPb37

Connection systems  
KHL P: cylindrical pin + safety R-clip

## Linear elements

code	cm	kg
RL105100A	106 x 67 x 100	41.5
RL105200A	106 x 67 x 200	62.5
RL105300A	106 x 67 x 300	83.5

## Gates and accessories

code		kg
KHLPZ1	Cylindrical pin + safety R-clip	0.2
C067RL	Pick up bar RL 105	9.9
RL105TT	RL 105 skate set - 2 pcs	7.5 On demand
RL 105X4	HL 105 rectangular 4 ways corner	75.2
MTS 52K02	Wheel set for sleeve block Set of 8 pcs	19.6
MTS 52R105	RL105 4 ways sleeve block Maxitower 52	94.8
MTS 52R105H	RL105 3 ways w/hoist support sleeve block - Maxitower 52	103.1
MTS 52K01	Guy-wires fastening to sleeve block - Set of 4 pcs	6.3

## Cantilever load table / Fork connection

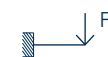

SPAN	Uniformly distributed load			Centre point load	
	m	kg / m	kg	mm	mm
2	1976	3952	1	3018	1
4	734	2936	4	2005	7
6	382	2290	11	1467	18
8	229	1831	22	1124	34
10	148	1479	36	882	54

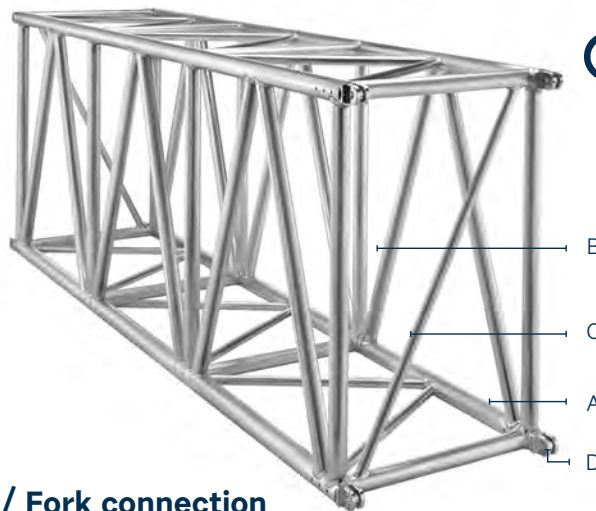

### Load table / Fork connection



SPAN	Unif. distributed load			Centre point load			Third point load			Quarter point load			Fifth point load		
	Point load	Full load	Central deflection	Point load	Full load	Central deflection	Point load	Full load	Central deflection	Point load	Full load	Central deflection	Point load	Full load	Central deflection
m	kg/m	kg	mm	kg	kg	mm	kg	kg	mm	kg	kg	mm	kg	kg	mm
3	3471	10414	1	9669	9669	1	5207	10414	1	3471	10414	1	2603	10414	1
4	2596	10386	1	8615	8615	2	5009	10018	2	3462	10386	2	2596	10386	2
5	2072	10358	3	7394	7394	3	4619	9238	3	3398	10193	4	2590	10358	3
6	1722	10330	5	6461	6461	5	4273	8546	5	3190	9569	6	2574	10294	6
7	1472	10303	8	5735	5735	7	3841	7683	8	3002	9005	9	2441	9764	9
8	1284	10275	12	5149	5149	9	3484	6969	11	2827	8482	12	2222	8887	12
9	1139	10247	16	4663	4663	12	3184	6368	14	2587	7761	16	2006	8024	16
10	990	9896	22	4255	4255	15	2927	5854	18	2340	7019	20	1826	7303	20
11	819	9005	27	3905	3905	19	2704	5409	22	2132	6395	24	1672	6689	24
12	687	8246	32	3603	3603	23	2509	5019	27	1954	5863	29	1540	6160	29
13	584	7591	38	3342	3342	27	2337	4674	32	1801	5403	34	1425	5698	34
14	501	7020	44	3108	3108	32	2183	4366	37	1667	5000	40	1323	5292	40
15	434	6516	50	2899	2899	37	2045	4090	43	1548	4645	46	1232	4926	46
16	379	6068	57	2711	2711	42	1920	3839	50	1442	4326	52	1151	4603	53
17	333	5666	65	2540	2540	48	1805	3611	57	1346	4039	59	1078	4311	60
18	295	5302	73	2387	2387	54	1704	3408	65	1262	3786	66	1011	4046	68
19	261	4968	81	2244	2244	61	1608	3216	72	1183	3548	74	951	3803	76
20	234	4671	90	2113	2113	68	1519	3038	81	1111	3332	82	895	3580	84
21	209	4392	99	1995	1995	75	1439	2877	90	1047	3140	91	844	3376	93
22	188	4135	109	1884	1884	83	1362	2723	99	986	2957	100	797	3190	102
23	169	3891	119	1779	1779	91	1290	2580	109	930	2791	109	752	3010	112
24	152	3660	129	1681	1681	100	1222	2443	119	877	2631	119	711	2843	122
25	138	3452	139	1589	1589	109	1160	2320	130	828	2483	129	672	2687	133
26	125	3254	150	1503	1503	118	1100	2201	141	781	2344	139	634	2538	143
27	114	3069	162	1421	1421	128	1044	2088	152	737	2210	150	601	2403	155
28	103	2897	173	1343	1343	138	991	1981	164	697	2090	162	568	2272	166
29	94	2730	185	1270	1270	149	940	1880	177	658	1974	173	537	2149	179
30	86	2573	198	1200	1200	160	891	1783	189	621	1863	185	508	2031	191
31	78	2424	210	1133	1133	171	845	1690	203	586	1757	198	480	1919	204
32	71	2283	223	1069	1069	183	801	1602	216	552	1657	210	453	1812	217
33	65	2148	237	1008	1008	196	759	1517	231	520	1561	224	427	1710	231

Load table has been prepared in accordance with UNI ENV 1999-1-1 (Eurocode 9). When calculating the allowable loads it is assumed that the load is suspended from the bottom chord and the truss is supported from the top chord at each end. The values shown in the table are the allowable static loads that can be applied to the truss. This is the live load or the payload.

The self weight of the truss has been taken into account when calculating the values in the table. It should be noted that this are idealised loading conditions and the User shall re-analyze the truss for the loading conditions which prevail for the application being considered.

High Load structures can be extended using specially designed accessories for suspension, transportation and reinforcement, including hooks, corner frames and skates. Only forked connectors with steel junction pins are used. Designed to withstand the highest stress and load levels, they offer guaranteed compatibility with the whole series.

Gates are short, flat section High Load elements generally used when putting together corners or tower sleeve blocks. Code numbers shown under the pictures refer to the shape and make it easy to identify.

## Connections



**KHLB**  
M20 screw bolt  
+ spring washer

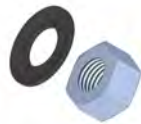

**KHLD**  
M20 screw nut  
+ spring washer



**KHLF**  
Female fork connector  
complete



**KHLG**  
M20 Lifting Eye



**KHLM**  
Male fork  
connector complete



**KHL P**  
Cylindrical pin  
+ 3 mm safety R-clip



**KHL180A**  
180° double fork aluminum  
connector



**KHL180S**  
180° double fork  
steel connector



**KHL90LA**  
90° double fork  
alum. connector, left



**KHL90LS**  
90° double fork steel  
connector, left



**KHL90RA**  
90° double fork alum.  
connector, right



**KHL90RS**  
90° double fork steel  
connector, right



**TZHL01**  
FL assembly kit

## Accessories

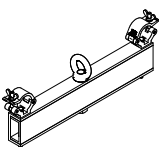

**C067RL**  
Pickup bar RL105



**MTS52K01**  
Guy-wires fastening to  
sleeve block Set of 4 pcs



**MTS52K02**  
Wheel set for sleeve block  
- Set of 8 pcs

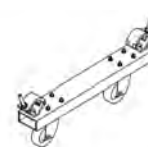

**RL105TT**  
RL 105 skate set 2 pcs

# Sleeve blocks

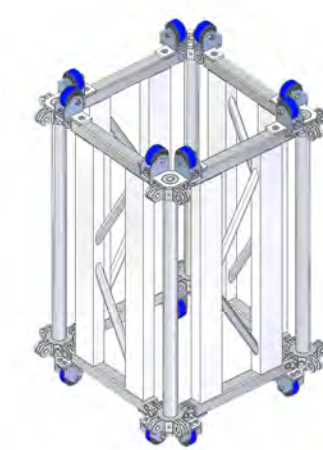
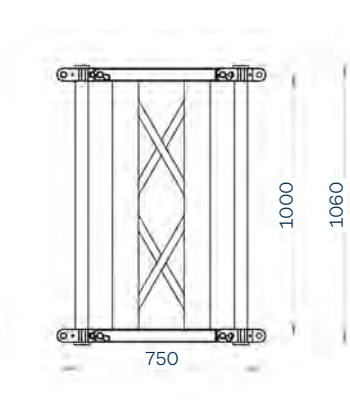
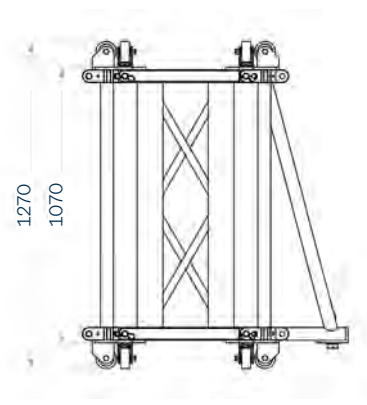
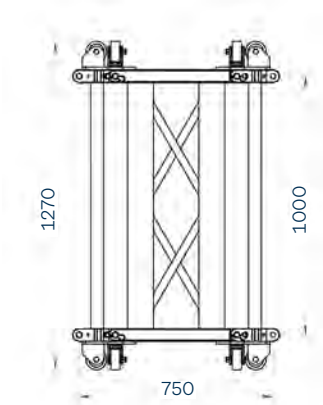
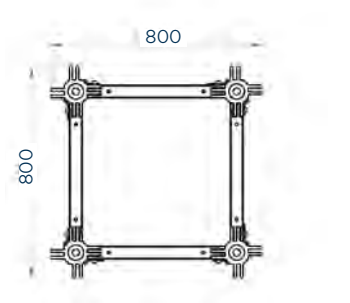
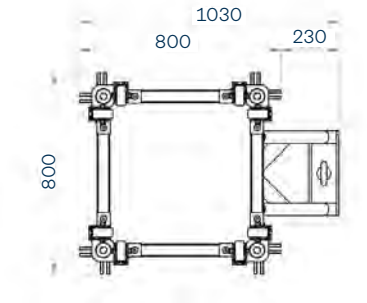
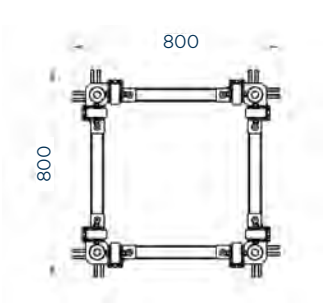

**MTS52R105**

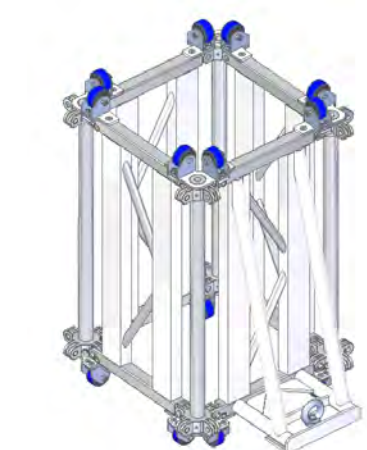

**MTS52R105H**



**RL105x4**

# MyT Virtue



MyT Virtue is a new truss that's the smallest member of the MyT family. Made from EN AW-7003 T6 aluminium alloy, it features a folding design to save space during transportation and has a higher load capacity than our RL105A series and all other truss on the market with similar dimensions. It's the perfect choice for larger, more demanding indoor and outdoor events.

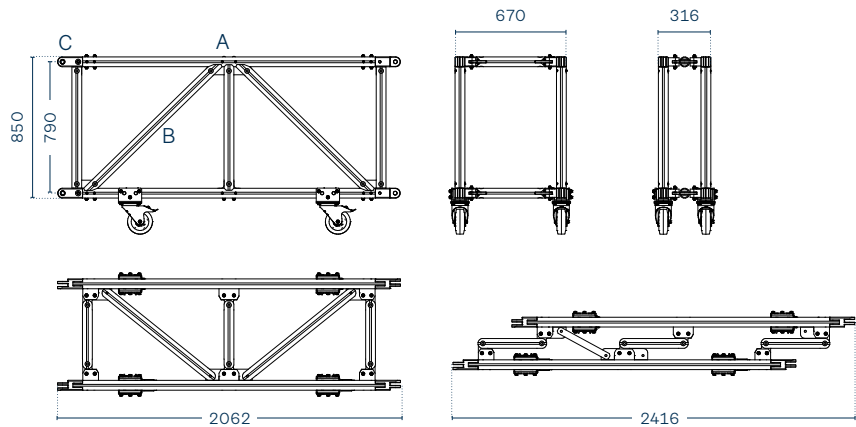

Chords A  
Extruded aluminium tube  $\varnothing$  60 mm  
EN AW-7003 T6

Diagonals B  
Extruded aluminium tube  $\varnothing$  60 mm  
EN AW-7003 T6

Ends C  
Aluminium forks connector  
EN AW-7003 T6

Connection system  
Steel  
11SMnPb37

Bolts  
cl. 10.9

Section area  
5.284 mm<sup>2</sup>

#### Linear elements

code	cm	kg
LT MF85200A	85 x 67 x 200	166
LT MF85300A	85 x 67 x 300	219



### Load table / Fork connection

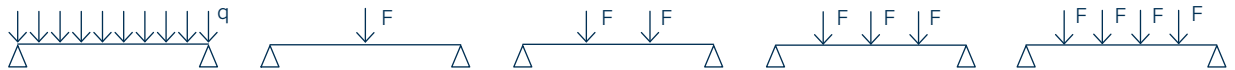

SPAN	Unif. distributed load			Centre point load			Third point load			Quarter point load			Fifth point load		
	Point load	Full load	Central deflection	Point load	Full load	Central deflection	Point load	Full load	Central deflection	Point load	Full load	Central deflection	Point load	Full load	Central deflection
m	kg/m	kg	mm	kg	kg	mm	kg	kg	mm	kg	kg	mm	kg	kg	mm
2	5047	10094	0.0	10094	10094	0.0	5047	10094	0.0	3365	10094	0.0	2524	10094	0.0
4	2492	9968	0.1	9381	9381	0.1	4984	9968	0.1	3323	9968	0.1	2492	9968	0.1
6	1640	9842	0.3	7980	7980	0.4	4628	9255	0.4	3281	9842	0.3	2460	9842	0.3
8	1214	9716	0.7	6916	6916	0.7	4117	8234	0.8	3043	9129	0.8	2429	9716	0.8
10	959	9590	1.3	6077	6077	1.3	3692	7384	1.3	2771	8313	1.4	2251	9003	1.5
12	789	9464	2.2	5394	5394	2.0	3332	6664	2.1	2534	7602	2.3	2079	8316	2.4
14	667	9338	3.5	4825	4825	3.0	3021	6043	3.2	2324	6973	3.4	1925	7698	3.5
16	576	9212	5.3	4341	4341	4.1	2749	5499	4.4	2137	6412	4.7	1785	7140	5.0
18	454	8168	6.9	3922	3922	5.5	2508	5016	5.9	1969	5906	6.4	1657	6629	6.8
20	356	7112	8.5	3554	3554	7.1	2292	4584	7.7	1778	5333	8.2	1482	5924	8.6
22	283	6224	10.4	3112	3112	8.7	2097	4194	9.7	1556	4668	9.9	1297	5187	10.4
24	228	5464	12.4	2732	2732	10.5	1919	3837	12.0	1366	4098	11.9	1138	4554	12.4
26	185	4802	14.6	2401	2401	12.5	1755	3509	14.5	1200	3601	14.0	1000	4001	14.7
28	151	4216	17.0	2108	2108	14.7	1581	3162	17.2	1054	3161	16.4	878	3513	17.1
30	123	3691	19.6	1846	1846	17.1	1384	2768	19.9	923	2768	19.0	769	3076	19.7

Load table has been prepared in accordance with UNI ENV 1999-1-1 (Eurocode 9). When calculating the allowable loads it is assumed that the load is suspended from the bottom chord and the truss is supported from the top chord at each end. The values shown in the table are the allowable static loads that can be applied to the truss. This is the live load or the payload. The self weight of

the truss has been taken into account when calculating the values in the table. It should be noted that this are idealised loading conditions and the User shall re-analyze the truss for the loading conditions which prevail for the application being considered.



Rectangular section High Load aluminium truss with extraordinary dimensions; it is 84 cm wide, 146 cm high and 500 cm long, and weighs 430 kg. It is made in high-performance aluminium alloy EN AW-7003 T6, among the aluminium series with the best mechanical characteristics. The truss can be used in large installations intended for entertainment, for temporary and semi-permanent structures. At maximum load spans it undergoes virtually no bending.

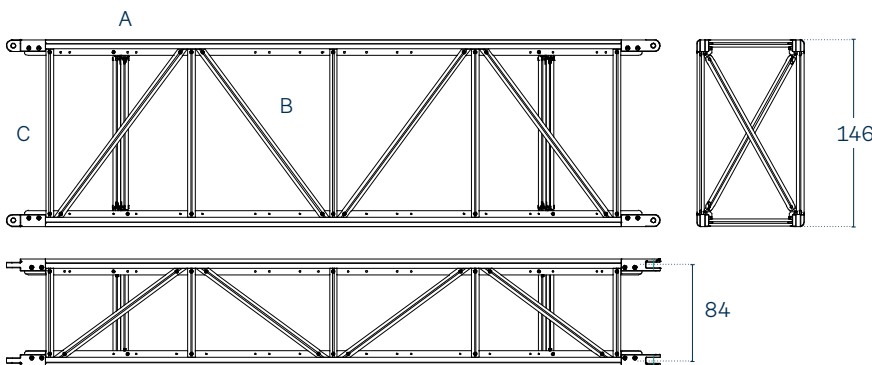

Chords A  
Extruded aluminium  
EN AW-7003 T6

Diagonals B  
Extruded aluminium  
EN AW-7003 T6

Ends C  
Aluminium forks connector  
EN AW-7003 T6

Connection system  
11SMnPb37

#### Accessories

code	
TR150M-A002	4 way connection kit
TR150M-A001	Trolley Skate 2 pc

#### Linear elements

code	cm	kg
TR150M-25M-A	84 x 146 x 250	233.5
TR150M-50M-A	84 x 146 x 500	430



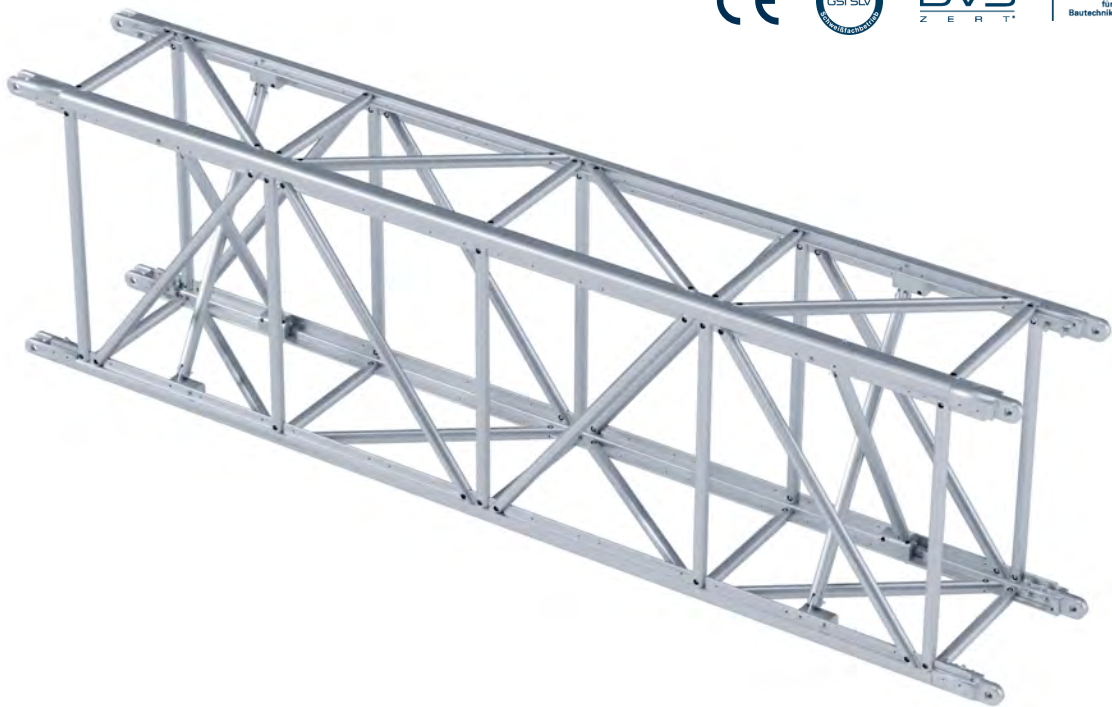

### Load table / Fork connection

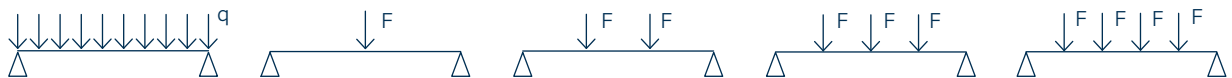

SPAN	Unif. distributed load			Centre point load			Third point load			Quarter point load			Fifth point load		
	Point load	Full load	Central deflection	Point load	Full load	Central deflection	Point load	Full load	Central deflection	Point load	Full load	Central deflection	Point load	Full load	Central deflection
m	kg/m	kg	mm	kg	kg	mm	kg	kg	mm	kg	kg	mm	kg	kg	mm
2	5039	10077	0	10076	10076	0	5039	10077	0	3359	10076	0	2519	10075	0
4	2476	9904	0.1	9905	9905	0.2	4953	9906	0.2	3302	9905	0.2	2476	9904	0.2
6	1623	9737	0.5	9734	9734	0.8	4867	9735	0.6	3245	9734	0.6	2433	9733	0.6
8	1196	9566	1.1	9563	9563	1.8	4782	9564	1.5	3188	9563	1.4	2390	9562	1.4
10	939	9388	2.2	9391	9391	3.4	4696	9392	3	3130	9391	2.8	2348	9390	2.7
12	769	9223	3.9	9220	9220	5.9	4611	9221	5.1	3073	9220	4.8	2305	9219	4.6
14	646	9048	6.1	9049	9049	9.4	4525	9050	8.1	3016	9049	7.6	2262	9048	7.3
16	555	8873	9.2	8878	8878	13.9	4439	8879	12	2959	8878	11.3	2219	8877	10.8
18	484	8716	13.1	8594	8594	19.4	4354	8707	17.1	2902	8706	16	2176	8705	15.4
20	427	8542	18	8134	8134	25.7	4268	8536	23.4	2845	8535	21.9	2134	8534	21.1
22	380	8365	24	1589	1589	33.1	4182	8365	31	2788	8364	29.1	2091	8363	28
24	341	8196	31.2	7305	7305	41.7	4097	8194	40.1	2731	8193	37.7	2048	8192	36.3
26	309	8031	39.8	6930	6930	51.4	4007	8014	50.8	2674	8021	47.9	2005	8020	46.2
28	280	7849	49.8	6577	6577	62.4	3819	7637	61.9	2617	7850	59.7	1962	7849	57.6
30	256	7676	61	6244	6244	75	3639	7278	74	2560	7679	73	1919	7678	71
32	234	7503	75	5928	5928	89	3466	6932	88	2503	7508	89	1877	7507	86
34	216	7348	90	5628	5628	104	3300	6599	104	2445	7336	106	2038	8151	103
36	199	7156	107	5327	5327	120	3139	6277	121	2351	7052	124	1791	7164	122
38	185	7011	126	4882	4882	135	2984	5967	139	2245	6734	144	1748	6993	143
40	170	6809	147	4472	4472	151	2834	5668	159	2141	6422	165	1705	6822	166

Load table has been prepared in accordance with UNI ENV 1999-1-1 (Eurocode 9). When calculating the allowable loads it is assumed that the load is suspended from the bottom chord and the truss is supported from the top chord at each end. The values shown in the table are the allowable static loads that can be applied to the truss. This is the live load or the payload. The self weight of

the truss has been taken into account when calculating the values in the table. It should be noted that this are idealised loading conditions and the User shall re-analyze the truss for the loading conditions which prevail for the application being considered.

# MyT Steroid



Rectangular section High Load aluminium truss with extraordinary dimensions; it is 84 cm wide, 146 cm high and 500 cm long, and weighs 430 kg. It is made in highperformance aluminium alloy EN AW-7003 T6, among the aluminium series with the best mechanical characteristics. Thanks to the double number of diagonals on the vertical faces, the Steroid version has better performances than the Regular version. The truss can be used in large installations intended for entertainment, for temporary and semi-permanent structures. At maximum load spans it undergoes virtually no bending.

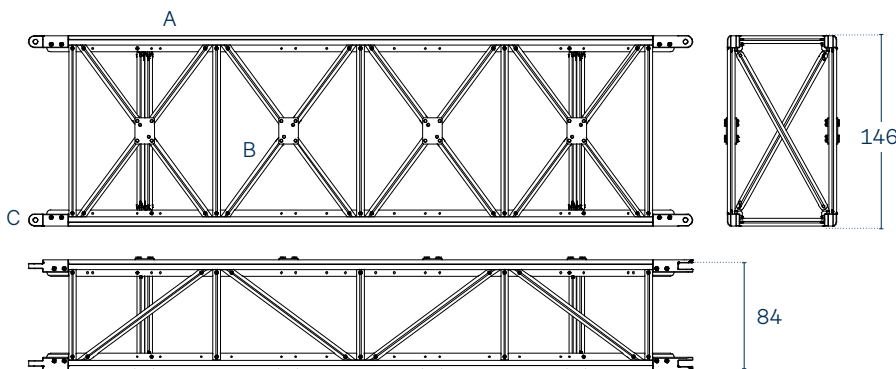

Chords A  
Extruded aluminium  
EN AW-7003 T6

Diagonals B  
Extruded aluminium  
EN AW-7003 T6

Ends C  
Aluminium forks connector  
EN AW-7003 T6

Connection system  
11SMnPb37

## Cantilever load table / Fork connection

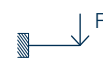

SPAN	Uniformly distributed load			Centre point load	
	m	kg / m	kg	mm	kg
1	15199	7600	0	7451	0
2	4871	7307	0	6906	0
3	2813	7038	0	6435	1
4	1938	6782	1	6025	2
5	1455	6547	1	5668	3

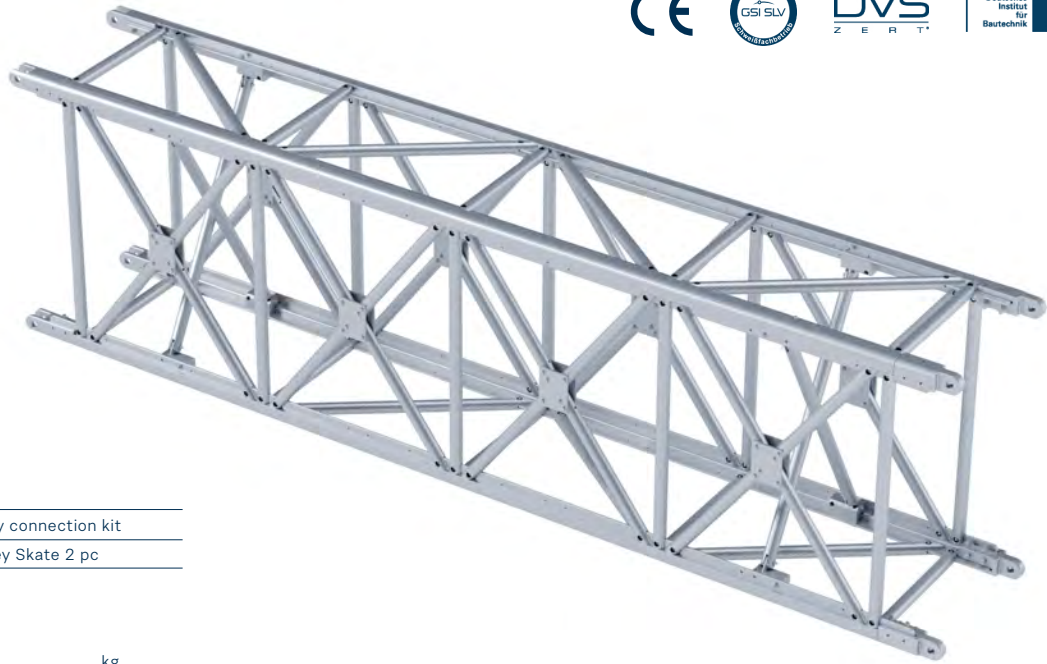

### Accessories

code	
TR150M-A002	4 way connection kit
TR150M-A001	Trolley Skate 2 pc

### Linear elements

code	cm	kg
TR150M-50M-G	84 x 146 x 500	495

## Load table / Fork connection

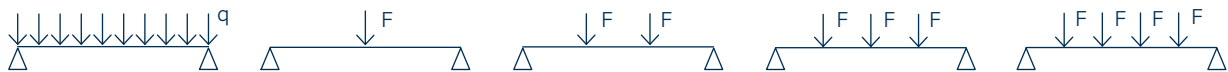

SPAN	Unif. distributed load			Centre point load			Third point load			Quarter point load			Fifth point load		
	Point load	Full load	Central deflection	Point load	Full load	Central deflection	Point load	Full load	Central deflection	Point load	Full load	Central deflection	Point load	Full load	Central deflection
m	kg/m	kg	mm	kg	kg	mm	kg	kg	mm	kg	kg	mm	kg	kg	mm
2	7671	15341	0	14332	14332	0	7324	14648	0	4938	14811	0	3729	14913	0
4	3792	15168	0	13303	13303	0	6929	13853	0	4720	14159	0	2587	14343	0
6	2499	14995	1	12396	12396	1	6565	13129	1	4514	13537	1	3451	13802	1
8	1853	14832	2	11590	11590	2	6228	12457	2	4319	12956	2	3321	13282	2
10	1466	14659	3	10877	10877	4	5916	11835	4	4136	12406	4	3197	12783	4
12	1207	14485	6	10224	10224	7	5626	11254	6	3961	11886	6	3077	12314	6
14	1022	14312	9	9633	9633	10	5353	10703	9	3795	11386	9	2962	11845	9
16	884	14139	14	9093	9093	14	5097	10194	14	3636	10907	14	2851	11407	14
18	776	13976	20	8594	8594	19	4855	9710	19	3484	10459	19	2745	10979	19
20	690	13802	27	8134	8134	26	4627	9254	25	3339	10017	25	2641	10571	25
22	620	13629	36	7705	7705	33	4410	8820	32	3200	9599	33	2541	10166	33
24	561	13456	47	7305	7305	42	4204	8408	41	3065	9197	42	2444	9779	42
26	511	13282	60	6930	6930	51	4007	8014	51	2936	8808	52	2351	9403	53
28	465	13007	74	6577	6577	62	3819	7638	62	2811	8434	63	2260	9038	64
30	421	12620	90	6244	6244	75	3639	7277	74	2691	8072	76	2170	8683	78
32	382	12232	108	5928	5928	89	3466	6932	88	2574	7723	91	2085	8337	93
34	338	11509	125	5628	5628	104	3300	6598	104	2461	7382	107	2000	8000	109
36	294	10561	141	5327	5327	120	3139	6277	121	2351	7053	124	1917	7672	128
38	255	9682	157	4882	4882	135	2984	5967	139	2245	6733	144	1838	7351	148
40	222	8876	175	4472	4472	151	2834	5669	159	2141	6421	165	1759	7038	170

Load table has been prepared in accordance with UNI ENV 1999-1-1 (Eurocode 9). When calculating the allowable loads it is assumed that the load is suspended from the bottom chord and the truss is supported from the top chord at each end. The values shown in the table are the allowable static loads that can be applied to the truss. This is the live load or the payload. The self weight of

the truss has been taken into account when calculating the values in the table. It should be noted that this are idealised loading conditions and the User shall re-analyze the truss for the loading conditions which prevail for the application being considered.

# MyT Folding Steroid



The MyT is a unique truss created from ultra-high strength EN AW-7003 aluminium alloy and benefits from an entirely bolted construction (no welded parts). For ease of transportation and handling, it is equipped with 4 large robust rubber wheels that allow the truss to be moved easily in many ground conditions. The MyT corner block is made from steel and is engineered to obtain the maximum load capacity from the truss in any configuration.

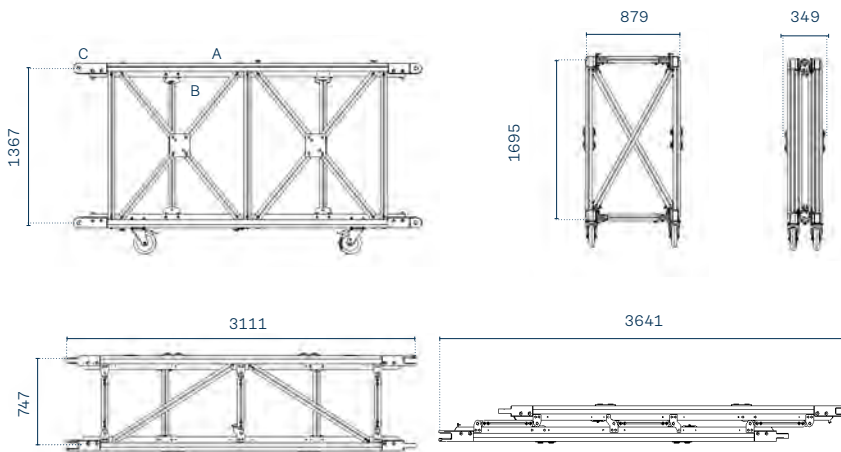

## Linear elements

code	cm	kg
TF150M-30M-A	84 x 146 x 300	326
TF150M-25M-A	84 x 146 x 250	300
TF150M-20M-A	84 x 146 x 200	230
TR150-C4	150 x 150 x 136.7	995
TR150-C4-2	150 x 150 x 136,7	404

Chords A  
Extruded aluminium  
EN AW-7003 T6

Diagonals B  
Extruded aluminium  
EN AW-7003 T6

Ends C  
Aluminium forks connector  
EN AW-7003 T6

Connection system  
11SMnPb37

## Cantilever load table / Fork connection



SPAN	Uniformly distributed load			Centre point load	
	kg / m	kg	mm	kg	mm
1	15199	7600	0	7451	0
2	4871	7307	0	6906	0
3	2813	7038	0	6435	1
4	1938	6782	1	6025	2
5	1455	6547	1	5668	3



### Load table / Fork connection

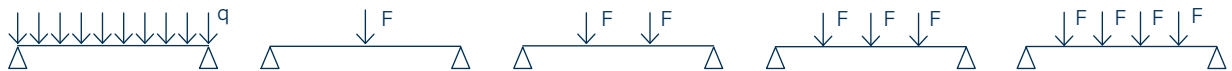

SPAN	Unif. distributed load			Centre point load			Third point load			Quarter point load			Fifth point load		
	Point load	Full load	Central deflection	Point load	Full load	Central deflection	Point load	Full load	Central deflection	Point load	Full load	Central deflection	Point load	Full load	Central deflection
m	kg/m	kg	mm	kg	kg	mm	kg	kg	mm	kg	kg	mm	kg	kg	mm
2	7671	15341	0	14332	14332	0	7324	14648	0	4938	14811	0	3729	14913	0
4	3792	15168	0	13303	13303	0	6929	13853	0	4720	14159	0	2587	14343	0
6	2499	14995	1	12396	12396	1	6565	13129	1	4514	13537	1	3451	13802	1
8	1853	14832	2	11590	11590	2	6228	12457	2	4319	12956	2	3321	13282	2
10	1466	14659	3	10877	10877	4	5916	11835	4	4136	12406	4	3197	12783	4
12	1207	14485	6	10224	10224	7	5626	11254	6	3961	11886	6	3077	12314	6
14	1022	14312	9	9633	9633	10	5353	10703	9	3795	11386	9	2962	11845	9
16	884	14139	14	9093	9093	14	5097	10194	14	3636	10907	14	2851	11407	14
18	776	13976	20	8594	8594	19	4855	9710	19	3484	10459	19	2745	10979	19
20	690	13802	27	8134	8134	26	4627	9254	25	3339	10017	25	2641	10571	25
22	620	13629	36	7705	7705	33	4410	8820	32	3200	9599	33	2541	10166	33
24	561	13456	47	7305	7305	42	4204	8408	41	3065	9197	42	2444	9779	42
26	511	13282	60	6930	6930	51	4007	8014	51	2936	8808	52	2351	9403	53
28	465	13007	74	6577	6577	62	3819	7638	62	2811	8434	63	2260	9038	64
30	421	12620	90	6244	6244	75	3639	7277	74	2691	8072	76	2170	8683	78
32	382	12232	108	5928	5928	89	3466	6932	88	2574	7723	91	2085	8337	93
34	338	11509	125	5628	5628	104	3300	6598	104	2461	7382	107	2000	8000	109
36	294	10561	141	5327	5327	120	3139	6277	121	2351	7053	124	1917	7672	128
38	255	9682	157	4882	4882	135	2984	5967	139	2245	6733	144	1838	7351	148
40	222	8876	175	4472	4472	151	2834	5669	159	2141	6421	165	1759	7038	170

Load table has been prepared in accordance with UNI ENV 1999-1-1 (Eurocode 9). When calculating the allowable loads it is assumed that the load is suspended from the bottom chord and the truss is supported from the top chord at each end. The values shown in the table are the allowable static loads that can be applied to the truss. This is the live load or the payload. The self weight of

the truss has been taken into account when calculating the values in the table. It should be noted that this are idealised loading conditions and the User shall re-analyze the truss for the loading conditions which prevail for the application being considered.





# Pre-Rig Trusses





## Functionality

LITEC offers two different system of PRE RIG. The standard PR60 let you save a lot of space during the transport and time in assembling. The new PR60 revolution is the evolution of the standard and it give to the designer the maximum flexibility for position the light.

PR60

PR60 Revolution

# PR60

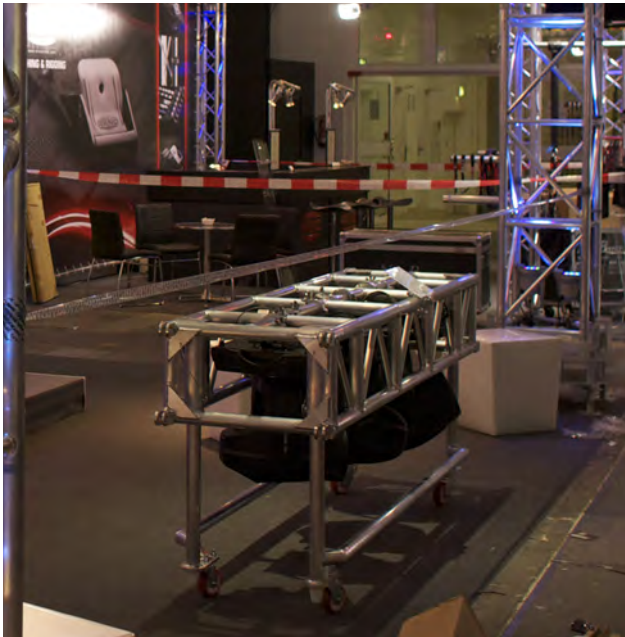

A pre-rig truss for supporting and transporting moving heads. It is equipped with 4 castor wheels for easy maneuverability and pins for the connection of truss pieces. Each truss is designed to carry a lighting bar complete with moving heads. The lighting bar is hooked onto the main chord and allows lights to move. This design reduces the amount of space required for rigging in the truck.

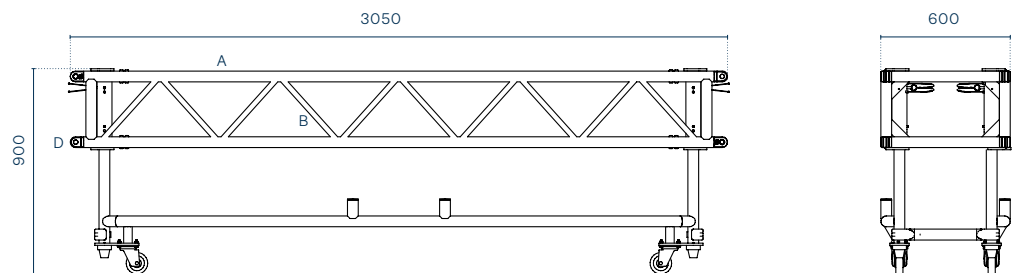

Chords A  
Extruded tube  $\varnothing$  50 x 4 mm  
EN AW-6082 T6

Diagonals B  
Extruded tube  $\varnothing$  25.4 x 3.2 mm  
EN AW-6082 T6

Ends C  
Aluminium forks connectors  
EN AW-6082 T6

Fixing points D  
Extruded tube  $\varnothing$  50 x 3 mm  
EN AW-6082 T6

Connection system KHL P  
Cylindrical pin + safety R-clip



### Load table / Fork connection

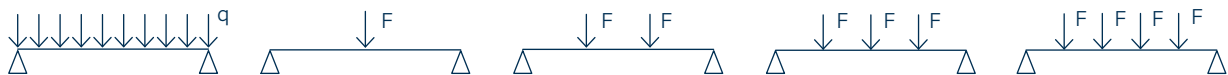

SPAN	Unif. distributed load			Centre point load			Third point load			Quarter point load			Fifth point load		
	Point load	Full load	Central deflection	Point load	Full load	Central deflection	Point load	Full load	Central deflection	Point load	Full load	Central deflection	Point load	Full load	Central deflection
m	kg/m	kg	mm	kg	kg	mm	kg	kg	mm	kg	kg	mm	kg	kg	mm
1	742	742	0	371	371	0	247	495	0	186	556	0	148	594	0
2	741	1482	1	408	408	0	408	815	0	370	1111	1	370	1481	1
3	734	2202	3	407	407	1	407	814	2	406	1217	2	406	1622	3
4	716	2865	9	407	407	2	406	812	4	404	1212	5	404	1614	7
5	619	3099	20	406	406	5	405	809	8	401	1203	10	401	1604	13
6	432	2590	29	405	405	8	403	806	13	398	1193	18	398	1591	22
7	313	2192	40	404	404	14	401	802	21	394	1181	28	394	1574	35
8	236	1889	53	402	402	21	399	797	32	389	1167	42	389	1557	52
9	184	1649	67	401	401	30	396	792	46	384	1152	60	344	1374	67
10	145	1445	82	398	398	42	393	786	64	361	1084	79	301	1204	83
11	116	1274	100	396	396	57	389	779	85	318	956	95	265	1062	100
12	94	1130	119	393	393	75	385	770	112	283	848	114	236	942	119
13	78	1007	140	390	390	97	378	755	142	252	755	134	210	840	140
14	64	899	162	387	387	123	378	755	165	224	674	156	188	750	163
15	54	804	187	383	383	154	301	603	190	201	603	180	167	669	188
16	45	719	213	360	360	184	269	540	216	180	540	206	150	600	214
17	38	643	242	321	321	210	241	483	245	161	483	234	134	536	243
18	32	573	272	287	287	239	215	431	276	144	431	264	119	478	274

The loads described above are related to the load applied on the central tube.

Load table has been prepared in accordance with UNI ENV 1999-1-1 (Eurocode 9). When calculating the allowable loads it is assumed that the load is suspended from the bottom chord and the truss is supported from the top chord at each end. The values shown in the table are the allowable static loads that can be applied to the truss. This is the live load or the payload. The self weight of

the truss has been taken into account when calculating the values in the table. It should be noted that this are idealised loading conditions and the User shall re-analyze the truss for the loading conditions which prevail for the application being considered.

High Load structures can be extended using specially designed accessories for suspension, transportation and reinforcement, including hooks, corner frames and skates. Only forked connectors with steel junction pins are used. Designed to withstand the highest stress and load levels, they offer guaranteed compatibility with the whole series.

Gates are short, flat section High Load elements generally used when putting together corners or tower sleeve blocks. Code numbers shown under the pictures refer to the shape and make it easy to identify.

## Connections



**KHLB**  
M20 screw bolt  
+ spring washer



**KHLD**  
M20 screw nut  
+ spring washer



**KHLF**  
Female fork connector  
complete



**KHLG**  
M20 Lifting Eye



**KHLM**  
Male fork  
connector complete



**KHLP**  
Cylindrical pin  
+ 3 mm safety R-clip



**KHL180A**  
180° double fork aluminum  
connector



**KHL180S**  
180° double fork  
steel connector



**KHL90LA**  
90° double fork  
alum. connector, left



**KHL90LS**  
90° double fork steel  
connector, left



**KHL90RA**  
90° double fork alum.  
connector, right



**KHL90RS**  
90° double fork steel  
connector, right



**TZHL01**  
FL assembly kit

## Accessories



**PR60LB150**  
**PR60LB235**  
**PR60LB300**  
Lighting bar for move the hanging point 10cm lower

## Gates



### PR60FP090

Flat truss to create vertical angles



### PR60FPV090

Flat truss to create horizontal angles

## Type of truss



### PR60TV

Vertical fixed forks



### PR60TN

90° Rotated fork



### PR60TR

360° Rotated forks

## Type of dolly



### PR60DF

Fixed height



### PR60DE

Adjustable height

## Corner solutions

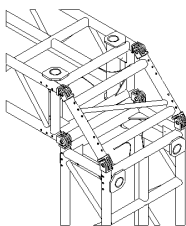

1

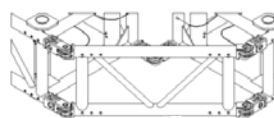

2

1 / 90° vertical corner

2 / 90° horizontal corner

# PR60 Revolution



The most innovative solution... basically a revolutionary way to carry moving lights mounted on pre rig type of trusses. Differently from the standard trusses, in this version the mounting of the moving lights can be done by one person only. Once the carriages equipped with Teflon skates is mounted on the moving light ...the latter can be easily slide into the truss along the two "C" profiles which acts as rail. A set of steel pins will fix the light into basically everywhere along the truss!!!

Each pre-rig "dolly" comes with foldable and adjustable in height legs; caster frames for easy transport and manoeuvrability during load in/out operations. To decrease storage space, dolly can be pile up one on the other.

Chords A  
Extruded tube  $\varnothing$  50 x 4 mm  
EN AW-6082 T6

Diagonals B  
Extruded tube  $\varnothing$  25.4 x 3.17 mm  
EN AW-6082 T6

Ends C  
Aluminium forks connectors  
EN AW-6082 T6

Fixing points D  
Extruded tube  $\varnothing$  50 x 50 x 3 mm  
EN AW-6082 T6

Connection system KHL P  
Cylindrical pin + safety R-clip

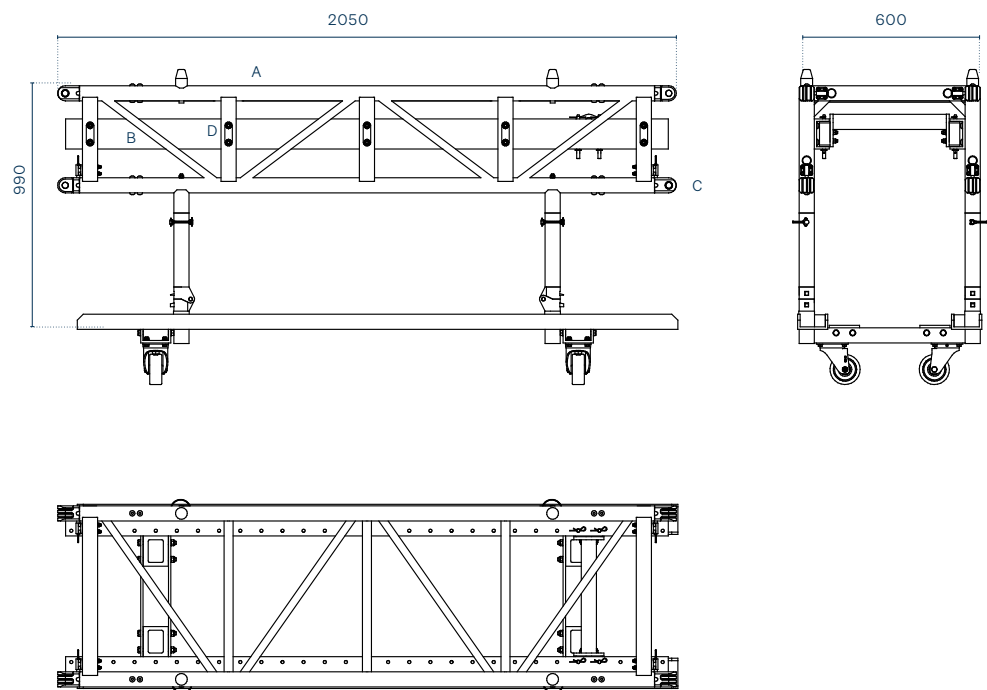



### Load table / Fork connection

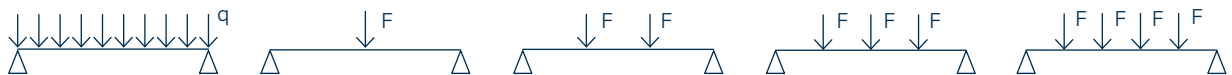

SPAN	Unif. distributed load			Centre point load			Third point load			Quarter point load			Fifth point load		
	Point load	Full load	Central deflection	Point load	Full load	Central deflection	Point load	Full load	Central deflection	Point load	Full load	Central deflection	Point load	Full load	Central deflection
m	kg/m	kg	mm	kg	kg	mm	kg	kg	mm	kg	kg	mm	kg	kg	mm
1	3008	3008	0	3008	3008	0	1504	3008	0	1003	3008	0	752	3008	0
2	1489	2978	0	2812	2812	1	1489	2978	1	993	2978	1	745	2978	1
3	983	2948	2	2248	2248	3	1391	2782	3	983	2948	3	737	2948	3
4	730	2918	6	1864	1864	6	1185	2371	7	917	2752	7	730	2918	8
5	578	2888	13	1583	1583	11	1027	2055	12	808	2425	13	681	2722	14
6	476	2858	22	1367	1367	17	902	1803	19	719	2158	21	593	2371	22
7	404	2828	35	1196	1196	25	799	1597	28	645	1934	31	516	2062	32
8	307	2452	47	1055	1055	34	712	1425	38	581	1743	43	453	1812	43
9	236	2123	60	937	937	44	638	1277	50	518	1554	56	401	1603	55
10	185	1853	74	836	836	57	574	1149	65	458	1375	71	357	1426	70
11	148	1627	90	748	748	71	518	1036	81	407	1220	87	318	1273	86
12	119	1434	108	671	671	87	467	935	99	358	1075	104	285	1139	105
13	97	1265	127	602	602	105	422	844	119	316	949	123	255	1019	125
14	80	1117	148	539	539	125	381	761	141	279	838	143	228	912	147
15	66	984	172	482	482	147	343	686	166	246	738	166	204	815	172
16	54	864	196	530	530	171	308	616	193	216	648	190	180	720	197
17	44	755	223	377	377	197	275	551	222	189	566	216	157	629	224
18	36	654	251	327	327	225	245	490	253	164	491	244	136	545	252
19	30	561	281	281	281	255	210	421	284	140	421	274	117	468	282
20	24	474	313	237	237	287	178	356	316	119	356	307	99	395	314

Load table has been prepared in accordance with UNI ENV 1999-1-1 (Eurocode 9). When calculating the allowable loads it is assumed that the load is suspended from the bottom chord and the truss is supported from the top chord at each end. The values shown in the table are the allowable static loads that can be applied to the truss. This is the live load or the payload. The self weight of

The loads described above are related to the load applied on the central tube.

the truss has been taken into account when calculating the values in the table. It should be noted that this are idealised loading conditions and the User shall re-analyze the truss for the loading conditions which prevail for the application being considered.

# PR60 Revolution

System

High Load structures can be extended using specially designed accessories for suspension, transportation and reinforcement, including hooks, corner frames and skates. Only forked connectors with steel junction pins are used. Designed to withstand the highest stress and load levels, they offer guaranteed compatibility with the whole series.

Gates are short, flat section High Load elements generally used when putting together corners or tower sleeve blocks. Code numbers shown under the pictures refer to the shape and make it easy to identify.

## Connections



**KHLB**  
M20 screw bolt  
+ spring washer

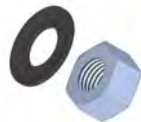

**KHLD**  
M20 screw nut  
+ spring washer



**KHLF**  
Female fork connector  
complete



**KHLG**  
M20 Lifting Eye



**KHLM**  
Male fork  
connector complete



**KHL P**  
Cylindrical pin  
+ 3 mm safety R-clip



**KHL180A**  
180° double fork aluminum  
connector



**KHL180S**  
180° double fork  
steel connector



**KHL90LA**  
90° double fork  
alum. connector, left



**KHL90LS**  
90° double fork steel  
connector, left



**KHL90RA**  
90° double fork alum.  
connector, right



**KHL90RS**  
90° double fork steel  
connector, right



**TZHL01**  
FL assembly kit



## Accessories

---

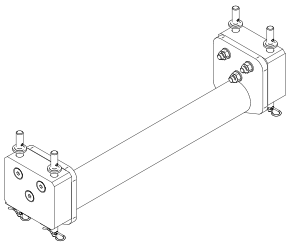

**PR60RC-002**

## Gates

---



**PR60FP090**

Flat truss to create vertical angles



**PR60FPV090**

Flat truss to create horizontal angles

## Corner solutions

---

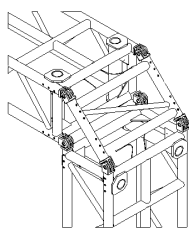

1

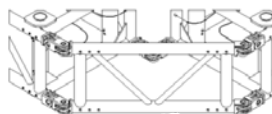

2

1 / 90° vertical corner

2 / 90° horizontal corner

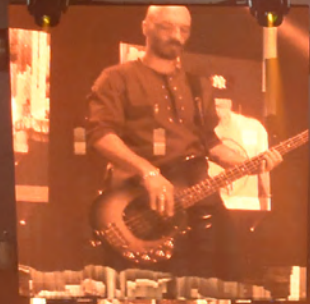



# Circles & Curved Trusses



## Unlimitedness

LITEC offers a wide range of circles and curved trusses, made in different diameters or degrees, for concerts, corporate events, exhibitions and many other events. Circles and curved trusses are produced with extreme accuracy and precision to guarantee perfect fitting. All curved parts are made with special tools ensuring that all parts are identical, so to allow every curved segment of a circle to be fully interchangeable.

There is no standard length for curved components. It is however preferable to limit each single component to no longer than 3.5 metres to make transport and handling easier.

END PLATED Circles Trusses

HIGH LOAD Circles Trusses

# END PLATED

## Circles Trusses

---

Apart from curves and circles, it is possible to build ellipses or irregular curved shapes. There are one solution for the square section, three for the triangular section and two for the flat section. There is no maximum diameter limit. LITEC advises the purchase of an even number of parts in order to obtain full flexibility and exchangeability with standard lengths and corner elements.

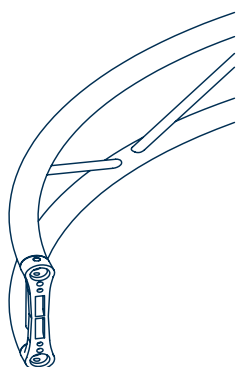

### FV

---

Vertical flat truss  
Available in:

- **FX25SA**
- **FX30SA**
- **FX40SA**

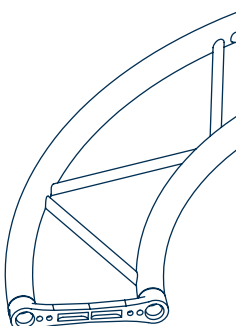

### FP

---

Horizontal flat truss  
Available in:

- **FX25SA**
- **FX30SA**
- **FX40SA**

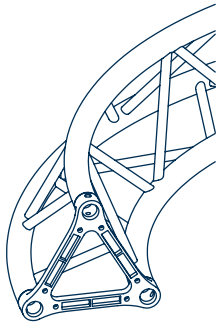

## T

Triangular truss with vertex on top  
Available in :

- **TX25SA**
- **TX30SA**
- **TX40SA**

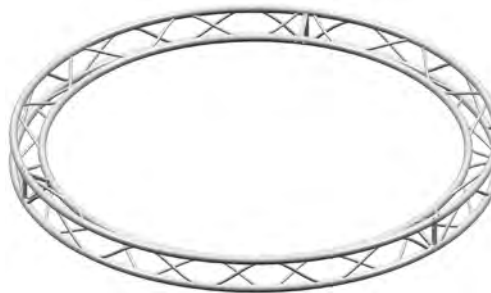
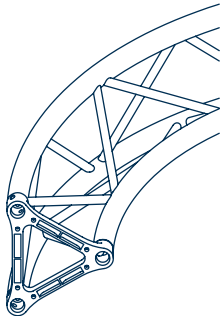

## TI

Triangular truss with internal vertex  
Available in:

- **TX25SA**
- **TX30SA**
- **TX40SA**

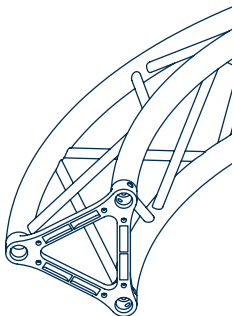

## TE

Triangular truss with external vertex  
Available in:

- **TX25SA**
- **TX30SA**
- **TX40SA**

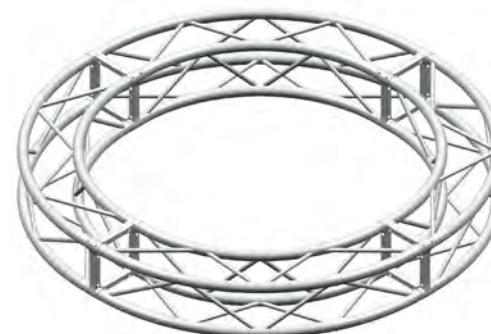
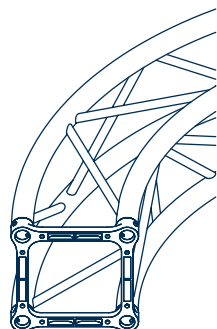

## Q

Square truss  
Available in:

- **QX25SA**
- **QX30SA**
- **QX40SA**
- **QH30SA**
- **QH40SA**

# HIGH LOAD

## Circles Trusses

---

Circles and curved trusses are also made with High Load trusses, load bearing trusses with universal fork connections for high-end solutions and excellent performances.

The circles are strong and sturdy, and there is no maximum diameter limit.

LITEC advises the purchase of an even number of parts in order to obtain full flexibility and exchangeability with standard lengths and corner elements. Circles are made in many High Load truss systems and formats such as RF40, QL40A, QL52A, QL76A, QL85A, RL76A, RL105A

**RF40**

---

**QL40A**

---

**QL52A**

---

**QL76A**

---

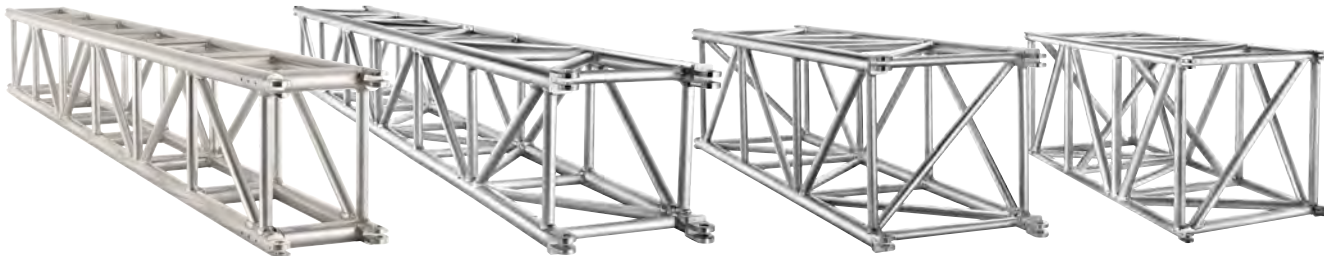

**QL85A**

---

**RL76A**

---

**RL105A**

---

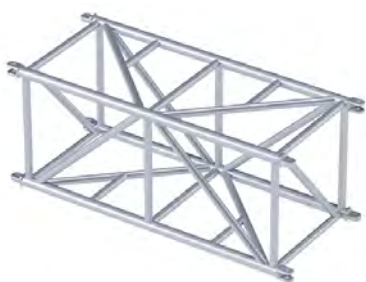



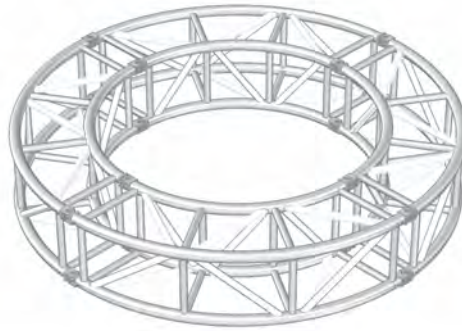
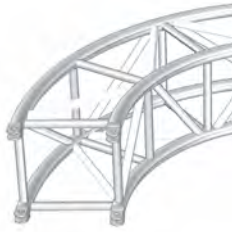

## QL40A

---

4 segments

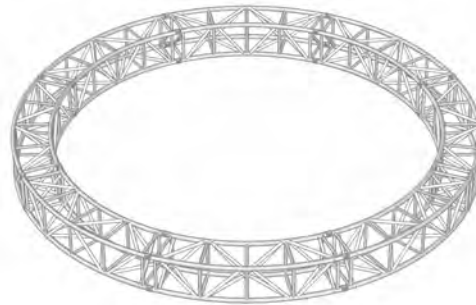

## QL52A

---

4 segments

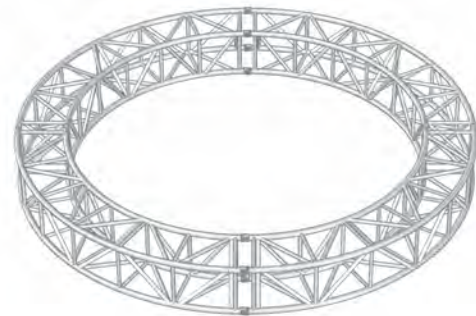
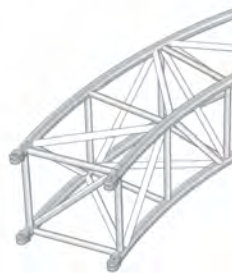

## QL76A

---

8 segments

Some examples of circles with fork connections





# Towers



## Solidity

LITEC offers one the most complete lines of towers; from the most compact telescopic to the most complex lifters used for High Load structures.

They are entirely pre-assembled modular ground supports, which combine structural soundness with a simple elegant design. Many tested and certified products are available to meet every need.

Towerlift 3  
Unitower  
Varitower 3  
Maxitower MT40  
Maxitower MT52  
Maxitower MT52HD  
Maxitower MT63  
Maxitower MT76  
Maxitower MT85

# Towerlift 3



The Towerlift 3 hoist system occurs by manual winch with steel cables. The sleeve block functions as default component also for the Unitower and Varitower models. Each side can accommodate either square truss of 29 cm or 40 cm sides, or triangular truss of 29 cm sides. A triangular truss of 40 cm may also be connected by substituting the appropriate central support plate.

Maximum tower height	→ 6.5 m
Lifting system	→ steel cable manual winch
Base module weight (included legs, top and sleeve block)	→ 75 kg
Vertical main truss	→ QX30SA
Compatible trusses	→ QX30SA / QH30SA / QX40SA / QH40SA / TX30SA
Base module height (excluding top)	→ 154 cm
Base module dimensions (folded versions)	→ 60 x 60 cm
Base module dimensions (operating version)	→ 180 x 180 cm
Volume	→ 0.6 m <sup>3</sup>
Adjustable legs	→ 4
Maximum lifting load capacity	→ 500 kg

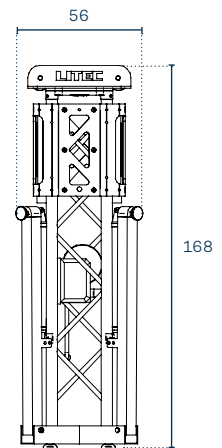
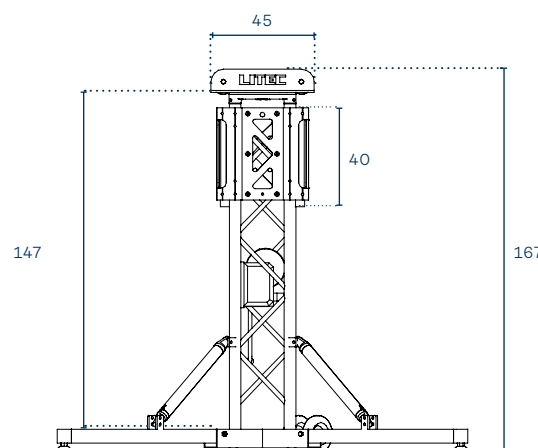
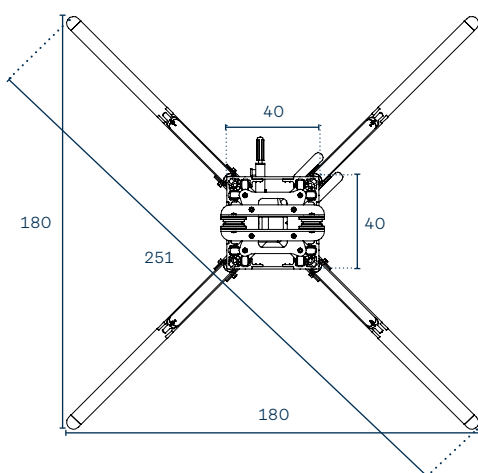

Towerlift 3 is supplied as standard with a steel cable manual winch. By using two accessories – the motor support and the extended top section – the tower can be used with a chain hoist lifter. Thus configured, the tower’s load capacity is 1000 kg.



## Towerlift 3

The top and leg adjustment mechanisms have been modified to give superb results. Each foot may be adjusted independently and extensively for easy positioning even on sloping and irregular surfaces. The 900 kg lifting power-clutch winch is protected inside the structure. During assembly, the wheels are never less than 100 cm from the ground.

The central structure is formed by the QX30SA truss. The sleeve block will accommodate connection to truss in series QX30SA, QX40SA, QH30SA, QH40SA, TX30SA. To connect with truss TX40SA the central support plate must be substituted on the corresponding side/s.

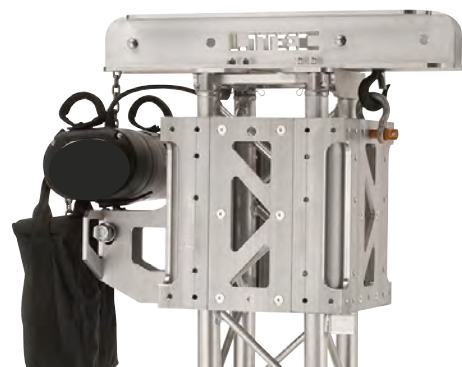

# Unitower



Base module for towers with frame of 29 cm sided square truss. The system comes furnished with detachable foldaway stabilizers. The multistandard sleeve block has 16 gliding wheels of high density rubber. Each foot moves both in pan and tilt so adapting to all terrain. The entire system, excluding the central truss, is formed of assembled parts, without any weldings.

Maximum tower height	→ 7 m
Lifting system	→ chain hoist
Base module weight (included legs, top and sleeve block)	→ 75 kg
Vertical main truss	→ QX30SA
Compatible trusses	→ QX30SA / QH30SA / QX40SA / QH40SA / TX30SA
Base module height (excluding top)	→ 90 cm
Base module dimensions (folded versions)	→ 60 x 60 cm
Base module dimensions (operating version)	→ 182 x 182 cm
Legs maximum extension	→ 97 cm
Maximum lifting load capacity	→ 1000 kg

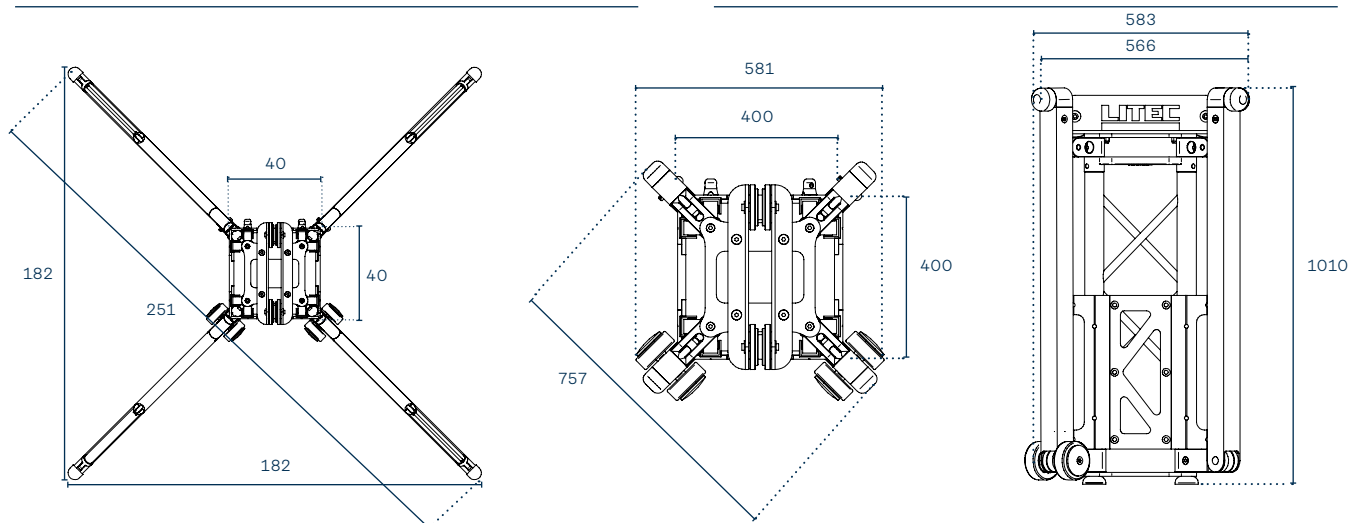





## Unitower

The sleeve block allows for the securing either of manual or electric motor hoists. Unitower is the only tower where the legs can be completely detached, leaving the vertical truss free without any jutting parts. The tower is designed to be composed of square truss QX30SA or QH30SA. The sleeve block however will take square truss

of 29 or 40cm sides, or triangular truss of 29cm sides.

In order to connect a triangular 40cm sided truss a substitute central support plate is needed. Every face is furnished with a series of holes for attachment of special steel spigots which allow a variety of diverse truss to be incorporated.

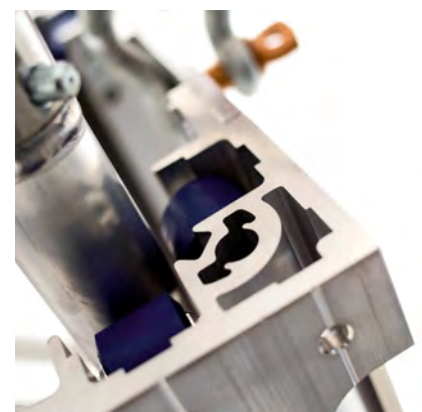

# Varitower 3



It substitutes the previous model Varitower 2. It can take a 29 or 40 m vertical truss, with the best performance seen from the QH40SA twist-resistant truss. The sleeve block is of the original design developed and tested for Unitower, with the same extruded profiles and the same applications.

Base module for towers, with frame in square truss of 29 or 40 cm sides.

The system is furnished with telescopic stabilizers, multistandard sleeve block with 16 gliding wheels in high density rubber, and top designed for chain feed.

	VT3-30	VT3-40
Maximum tower height	→ 8 m	→ 9 m
Lifting system	→ chain hoist	→ chain hoist
Base module weight (included legs, top and sleeve block)	→ 140 kg	→ 145 kg
Vertical main truss	→ QH30SA	→ QH40SA
Compatible trusses	→ QX30SA / QH30SA / QX40SA / QH40SA / TX30SA (TC40SA only for VT3-40)	
Base module dimensions (folded versions)	→ 130 cm	→ 130 cm
Base module dimensions (operating versions)	→ 240 x 240 cm	→ 240 x 240 cm
Leg maximum extension	→ 97 cm	→ 97 cm
Maximum lifting load capacity	→ 1800 kg	→ 2000 kg

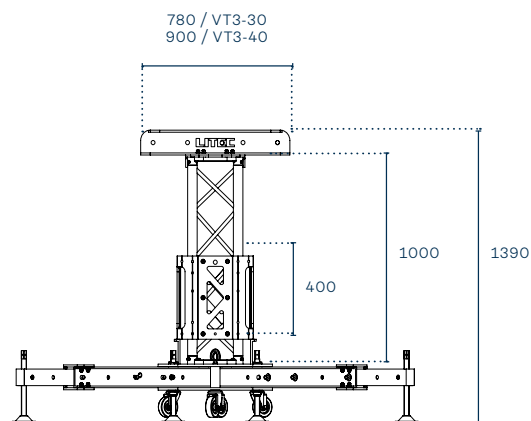
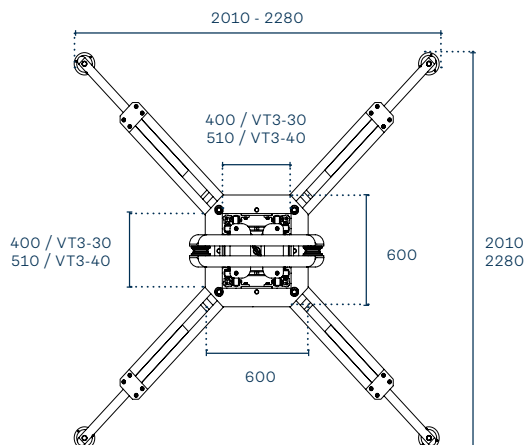



## Varitower 3

The complete system, except the central truss, is composed of assembled parts, without any weldings.

Varitower 3 can use only chain hoist systems, be they manual or electric. For either system the corresponding support is available. The base is made entirely of aluminium, and has telescopic legs with new adjustable feet.

Each leg can be moved horizontally in two directions for precise positioning.

Once assembly is completed the legs may be removed entirely from the base.

## Vari-Winch



# Maxitower MT40



Lifter able to carry loads up to 2,000 kg.  
If configured appropriately, the Maxitower 40 system interfaces with all types of LITEC truss sized from 29 to 76 cm.

	MT40	MT40E
Maximum tower height	→ 12 m	→ 9 m
Lifting system	→ chain hoist	→ chain hoist
Base module weight with top (excluding sleeve block and legs)	→ 86 kg	→ 56 kg
Vertical main truss	→ QL40A / QH40SA	→ QL40A
Compatible trusses (with suitable sleeve block)	→ FL52/FL76/QL40A/QL52A/RL76A	
Base dimensions	→ 60 x 60 cm	→ 40 x 40 cm
Volume	→ 0.58 m <sup>3</sup>	→ 0.24 m <sup>3</sup>
Maximum lifting load capacity	→ max 2000 kg	→ max 2000 kg

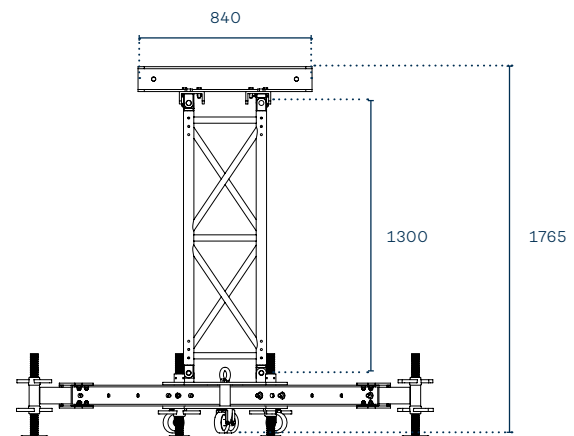
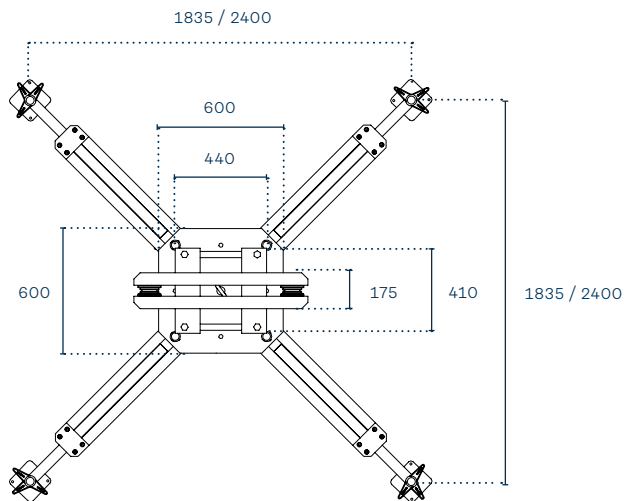



## Maxitower MT40

Stabilizers, motor supports and other special accessories complete the range.

The MT40 lifter can take all the trusses in the QL40A and QH40SA lines.

Also available in the compact-base MT40E version, particularly useful for putting together fair stands and indoor use.

The MT40 tower is composed of a base, extending stabilizers (that cover a maximum floor area of 2.4 m x 2.4 m), a main tower body that reached up to 12m in height, a top section with pulleys for electric chain hoists, and a modular sleeve block that can be assembled in different ways depending on application.

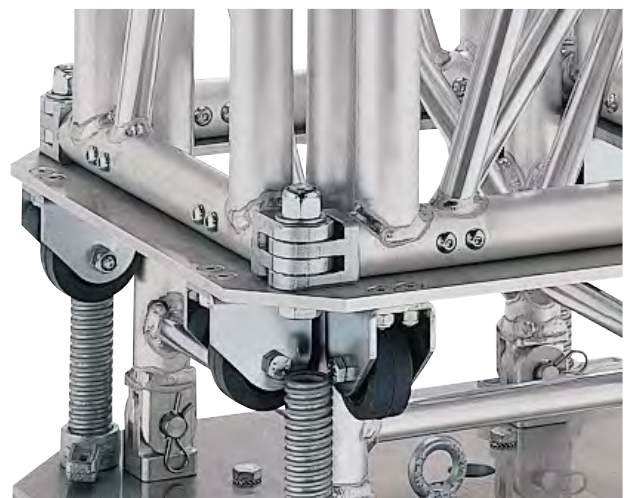
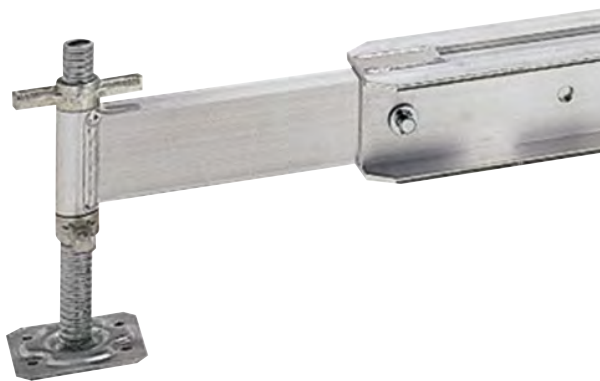

# Maxitower MT52



For lifting where high performance is needed. This model also comes in a compact-base Maxitower 52E version suitable for indoor use.

The base can take QL40A and QL52A series trusses. The four foot bars are telescopic, positionable, individually adjustable and extractable.

	MT52	MT52E
Maximum tower height	→ 15 m	→ 12 m
Lifting system	→ chain hoist	→ chain hoist
Base module weight with top (excluding sleeve block and legs)	→ 110 kg	→ 52 kg
Vertical main truss	→ QL52A	→ QL52A
Compatible trusses (with suitable sleeve block)	→ FL52 / FL76 / QL40A / QL52A / RL76A	
Base dimensions	→ 73 x 73 cm	→ 52 x 52 cm
Volume	→ 0.84 m <sup>3</sup>	→ 0.29 m <sup>3</sup>
Maximum lifting load capacity	→ max 3000 kg	→ max 3000 kg

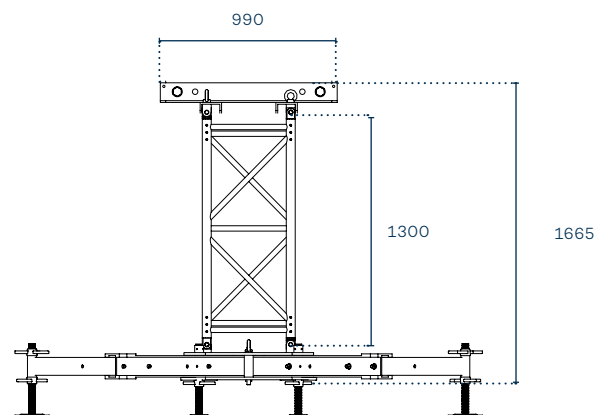
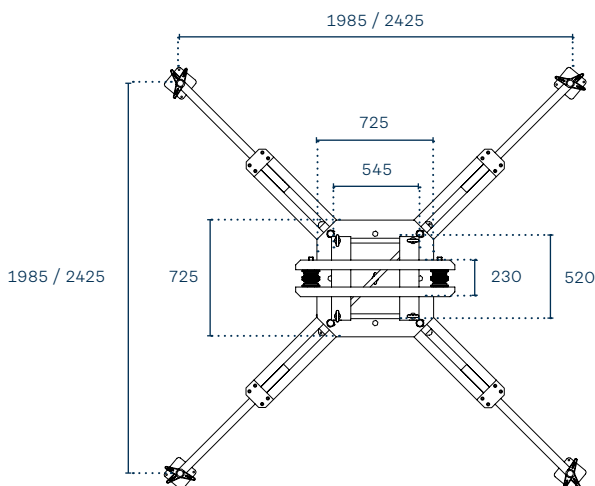



## Maxitower MT52

The system uses twist-resistant vertical 40 or 52 components, and comes complete with stabilization, motor coupling, hanging and safety accessories.

The MT52 tower is composed of a base, extending stabilizers (that cover a maximum floor

area of 2.4 m x 2.4 m), a main tower body that reaches up to 15m in height, a top section with pulleys for electric chain hoists, and a modular sleeve block that can be assembled in different ways depending on application.

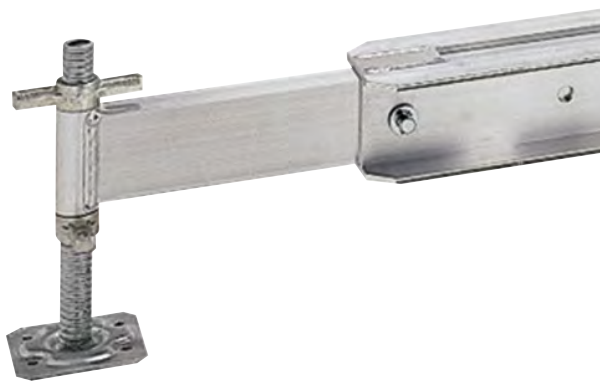

# Maxitower MT52HD



The Maxitower 52HD is a high performance, high capacity tower for your large and demanding projects. Made from EN AW 6082 T6 aluminium, it has the same dimensions as the Maxitower 52 but features  $\varnothing 60 \times 5$  mm main chords for achieving higher load capacities. Thanks to these unchanged dimensions, it's compatible with the standard Maxitower 52 sleeve block.

Lifting system

→ chain hoist

Base module weight with top  
(excluding sleeve block and legs)

→ 192.5 kg

Vertical main truss

→ QL52D

Compatible trusses  
(with suitable sleeve block)

→ QL52A - RL76A - RL105A

Base dimensions

→ 73 x 73 cm

Volume

→ 0.84 m<sup>3</sup>

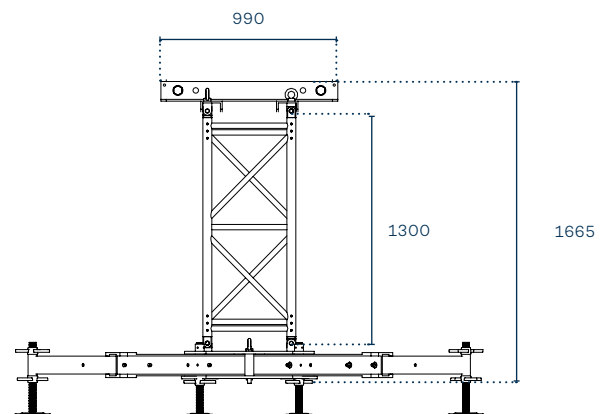
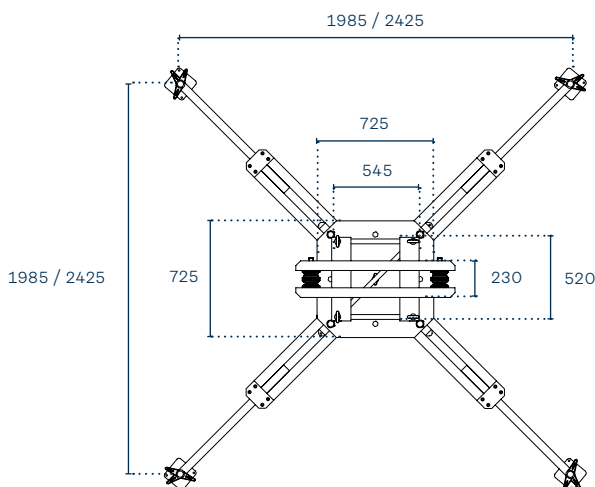



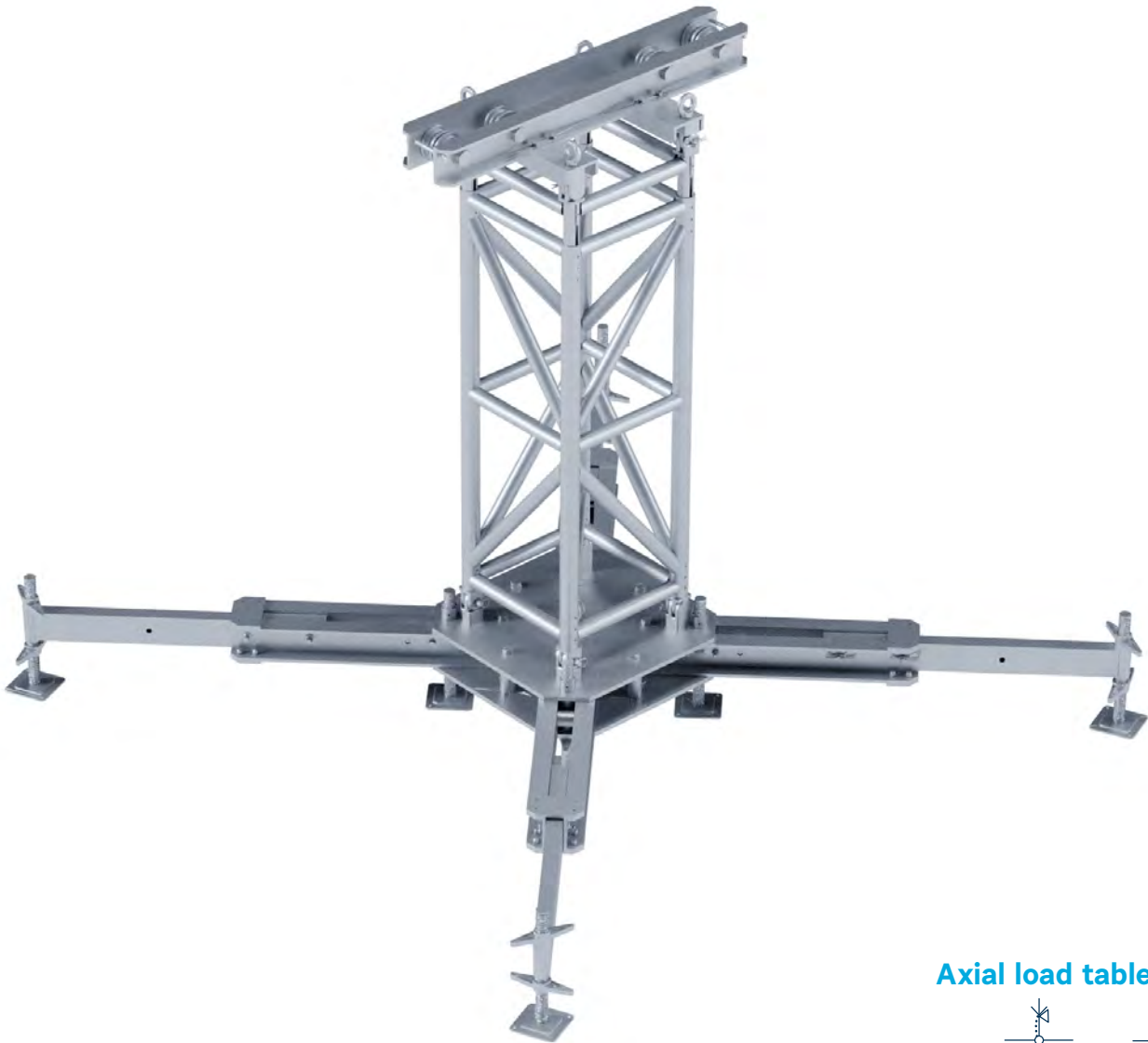

### Axial load table

SPAN		
	F <sub>am.</sub>	F <sub>am.</sub>
m	kg	kg
1	9572	9291
2	9542	8984
3	9514	8673
4	9477	8358
5	9435	8038
6	9387	7715
7	9334	7388
8	9275	6695
9	9211	5221
10	9141	4010
11	9067	
12	8986	
13	8900	
14	8809	
15	8712	
16	8186	
17	7315	
18	6514	
19	5776	
20	5094	

## Maxitower MT52HD

- Use of beefier  $\varnothing 60 \times 5$  mm main chords for increased load bearing
- New, super heavy-duty mechanical safety block
- Same overall dimensions as Maxitower 52
- Compatible with Maxitower 52 standard sleeve block
- Constructed from EN AW 6082 T6 aluminium

# Maxitower MT63



The Maxitower MT63 is the new tower for the MyT Virtue truss system. Featuring LITEC's innovative safety block with telescopic tube, it provides unrivaled levels of convenience and safety. With a maximum height of 25 metres and load capacity of 11.5 tons at 15 metres, the MT63 is the right choice for your very large and demanding projects.

Maximum tower height

→ 25 m

Lifting system

→ chain hoist

Vertical main truss

→ QL63A

Compatible trusses  
(with suitable sleeve block)

→ MyT Virtue

Maximum lifting load capacity

→ 11.5 tons @ 15 m

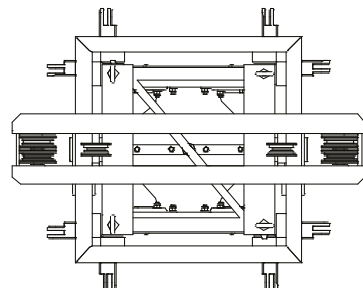
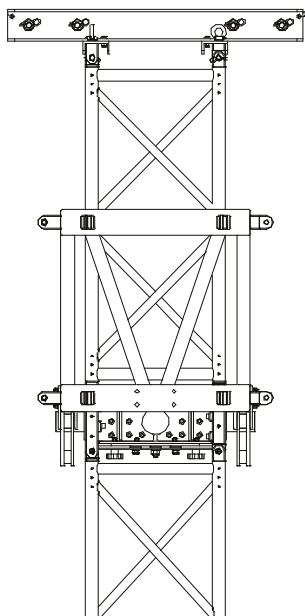





## Maxitower MT63

- Ø 60 x 5 mm main chords for increased load bearing
- New mechanical safety block with telescopic tube
- Constructed from EN AW 6082 T6 aluminium

### Axial load table

SPAN		
	F <sub>am.</sub>	F <sub>am.</sub>
m	kg	kg
1	12386	12093
2	12355	11768
3	12319	11436
4	12278	11099
5	12232	10757
6	12180	10409
7	12123	10056
8	12061	9200
9	11993	7512
10	11920	6053
11	11842	4796
12	11759	3711
13	11670	
14	11576	
15	11476	
16	10829	
17	9886	
18	8994	
19	8153	
20	7362	
21	6618	
22	5918	
23	5258	
24	4636	
25	4046	

# Maxitower MT76



The lifter uses QL76A trusses. It was designed to withstand the stresses that large structures transfer to the ground in their heaviest duty use.

It is intended for use together with the LIBERA FL105 system.

Maximum tower height	→ 20 m
Lifting system	→ chain hoist
Base module weight with top (excluding sleeve block and legs)	→ 165 kg
Vertical main truss	→ QL76A
Compatible trusses (with suitable sleeve block)	→ FL105
Base dimensions	→ 76 x 76 cm
Volume	→ 0.58 m3
Maximum lifting load capacity	→ max 4000 kg

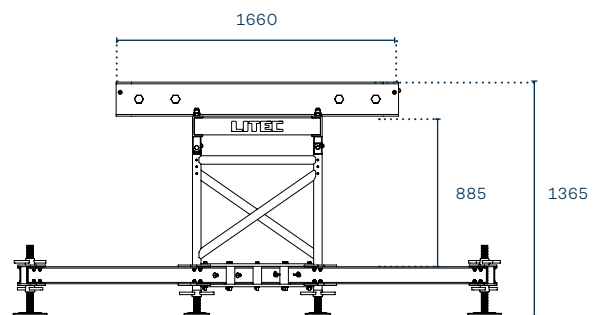
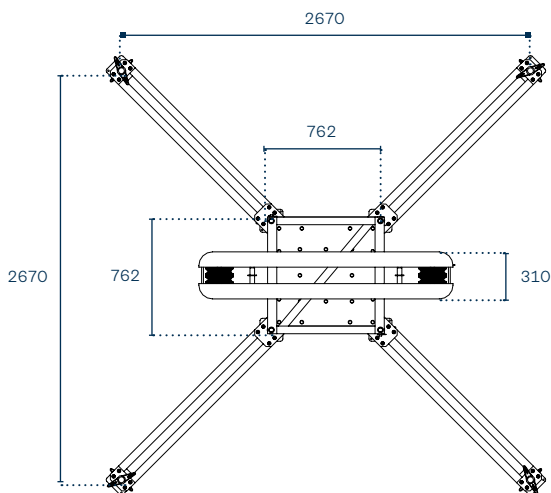



## Maxitower MT76

It is connected to LIBERA FL105 and RL105A through special trucks, which are available with or without motor supports. The MT76 tower is composed of a base, extending stabilizers (that cover a maximum floor area of 2.7 m x 2.7 m), a main tower body that reaches up to 20 m in height, a top section with pulleys for electric chain hoists, and a modular sleeve block that can be assembled in different ways depending on application.

# Maxitower MT85



The QL85 high performance tower system has been specifically developed for use with MyT truss.

QL85 encompasses many advanced features including the LITEC modular ballast base support system and the innovative mechanical safety lock - which offers a fast, safe and reliable method of securing the sleeve block at working height.

Maximum tower height	→ 25 m
Lifting system	→ chain hoist
Vertical main truss	→ QL85A
Compatible trusses (with suitable sleeve block)	→ MyT Folding Steroid
Base dimensions	→ 910 x 910 mm
Volume	→ 1 m <sup>3</sup>
Maximum lifting load capacity	→ max. 12000 kg

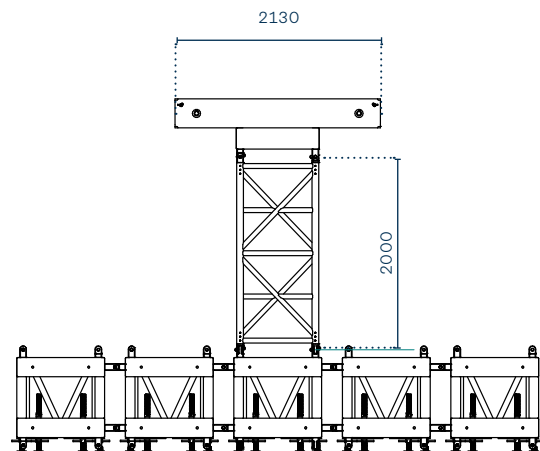
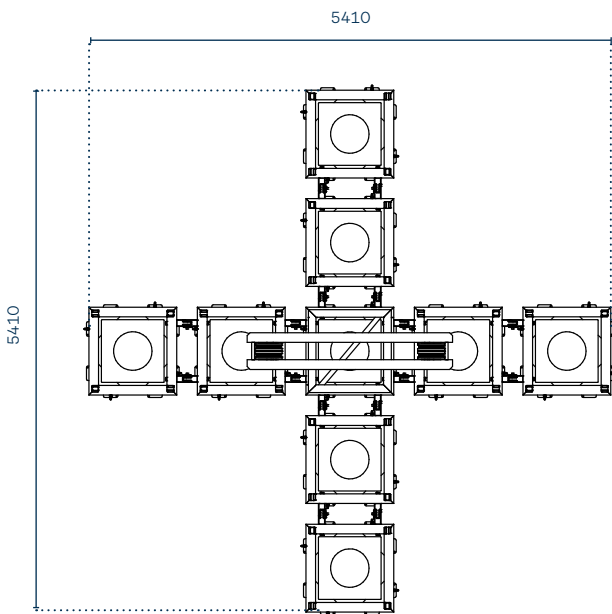

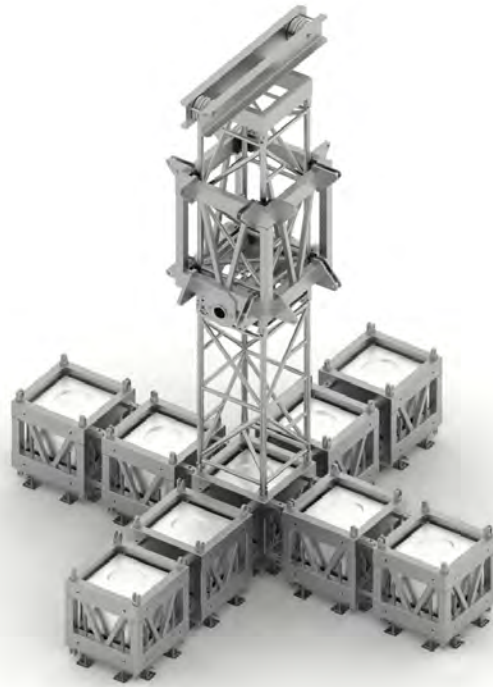

## Maxitower MT85 Parts



### Sleeve block

Multi-directional sleeve block with a mechanical safety lock system that secures the block from drop and lift when used in conjunction with our Safety Block.  
Weight-965 kg



### Safety block

Mechanical locking system for use with our SLEEVE BLOCK with telescopic tube and an easily accessible lever mechanism.  
Weight-335 kg



### Chain hoist support

Aluminum assembly for easy mounting of an electric chain hoist to the sleeve block.  
Weight-102 kg



### Tower top

Tower Top mounting assembly in steel with a double aluminum pulley system.  
Load capacity-5000 kg



### Ballast base

Modular steel ballast base support system\*. Modular connections on all sides.  
Weight-500 kg



### Ballast base connection kit

Allows connection to all sides of the ballast base block, either directly to other ballast modules or for the connection of truss.  
Weight  
MBS-KF01 8 kg  
MBS-KA01 23.5 kg  
MBS-KA02 26.5 kg

\* Concrete ballast block not included

## Axial load table

SPAN	$F_{am}$	$F_{am}$
m	kg	kg
9	25209	14213
10	24548	12417
11	23823	10854
12	23038	9508
13	22201	8352
14	21323	7358
15	20415	
16	19490	
17	18560	
18	17636	
19	16727	
20	15842	
21	14987	
22	14165	
23	13379	
24	12631	
25	11921	





