



## FUZE WASH Z350™

SKU# FUZ035

The FUZE WASH Z350™ is a single source par moving head luminaire with a 350W Quad Color RGBW COB LED. Features 6° to 46° motorized zoom, pan and tilt, RGBW color mixing, electronic strobe and selectable dimming curve effects, DMX and RDM (remote device management) protocol support, DMX and Locking power in/out connections, LCD menu display with 7 button control panel, multiple unit power linking, flicker free operation for TV and FILM, and a multi-voltage universal auto switching power supply (110-240v).

### FEATURES

**350W RGBW COB LED Moving Head Wash Luminaire**

**RGBW Color Mixing**

**6° to 46° Motorized Zoom Range**

**Variable Dimming Curves**

**Multiple Unit Power Linking**

**RDM (Remote Device Management)**

**Flicker Free Operation for TV and FILM**

**Optional Snoot Lens**



**SPECIFICATIONS**

**SOURCE**

350W RGBW COB LED

100,000 Hour Average LED Life\*

\*May vary depending on several factors including but not limited to: Environmental Conditions, Power/Voltage, Usage Patterns (On-Off Cycling), Control and Dimming.

**PHOTOMETRIC DATA**

60,280 LUX 5,600 FC @6.6' (2m) (6° Full ON)

3,735 LUX 347 FC @6.6' (2m) (46° Full ON)

**EFFECTS**

RGBW Color Mixing

6° - 46° Beam Zoom Range

Electronic Strobe and Variable Dimming Curves

64 Color Presets and 14 Unique Color Macros

**COLOR**

RGBW

**CONTROL / CONNECTIONS**

4 DMX Channel Modes (19 Total Channels)

7 Button Control Panel and LCD Menu Display

RDM (Remote Device Management)

3pin/5pin DMX and Locking Power Cable In/Out

**SIZE / WEIGHT**

Length: 16.3" (414mm)

Width: 11.6" (294mm)

Vertical Height: 22.7" (578mm)

Weight: 43 lbs. (19.5 kg)

**ELECTRICAL / THERMAL**

AC 110-240V - 50/60Hz

399W Max Power Consumption

Multiple Unit Power Linking

5°F to 113°F (-15°C to 45°C)

**INCLUDED ITEMS**

Omega Brackets

Locking Power Cable

**APPROVALS / RATINGS**



Optional Snoot Available



**PHOTOMETRIC DATA**

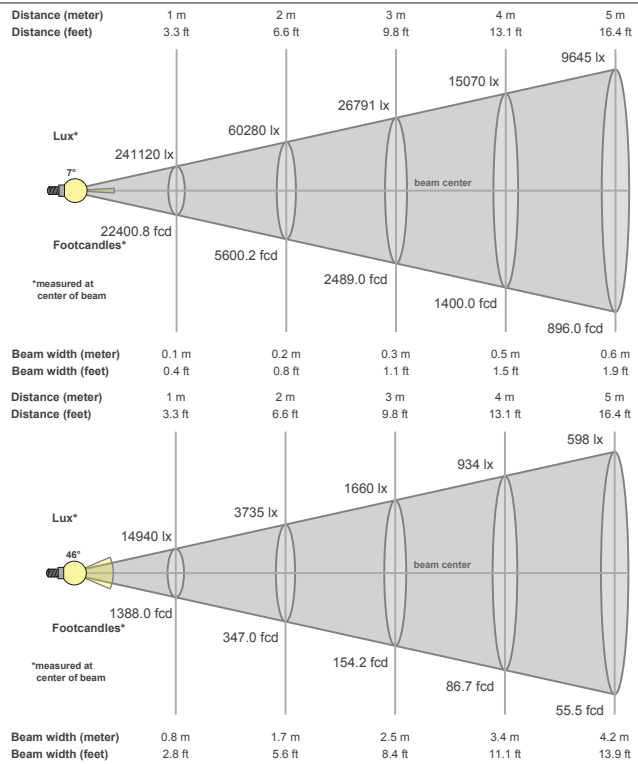

**DIMENSIONAL DIAGRAMS**

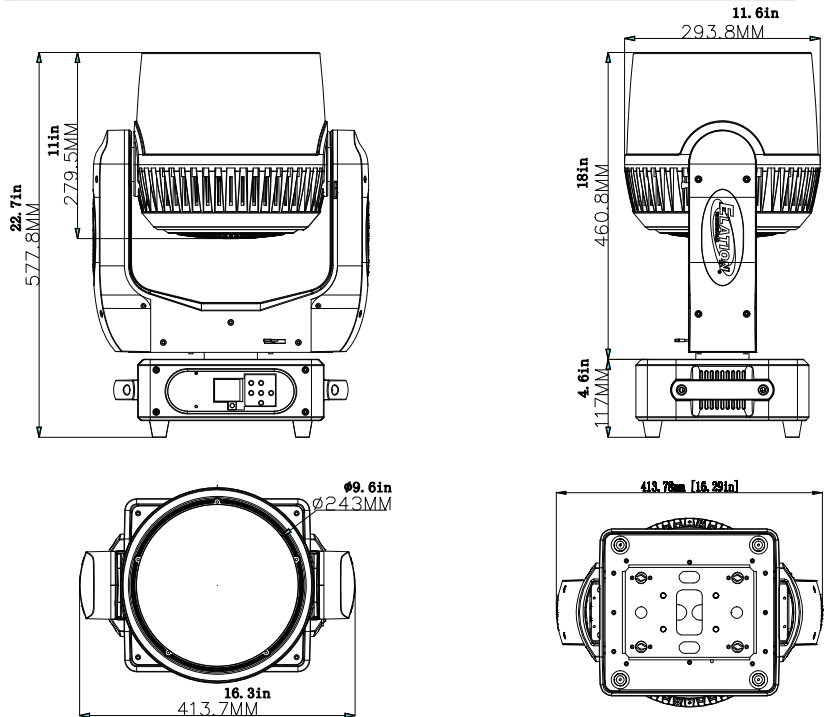

**OPTIONAL ACCESSORIES**

ORDER CODE	ITEM
FW350SNOOT	FUZE WASH Z350 Snoot
TRIGGER CLAMP	Heavy Duty Wrap Around Hook Style Clamp
AC3PDMX5PRO	5 ft. (1.5m) 3pin PRO DMX Cable (Additional cable lengths available)
AC5PDMX5PRO	5 ft. (1.5m) 5pin PRO DMX Cable (Additional cable lengths available)
PLC3	3 ft. (1m) Locking Power Link Cable
DRC350FUZE	Quad Road Case for FUZE WASH Z350



Specifications are subject to change without notice ©Elation Professional 10/10/19

Elation Professional USA | 6122 S. Eastern Ave. | Los Angeles, CA. 90040  
323-582-3322 | 323-832-9142 fax | www.elationlighting.com | info@elationlighting.com

Elation Professional B.V. | Junostraat 2 | 6468 EW Kerkrade, The Netherlands  
+31 45 546 85 66 | +31 45 546 85 96 fax | www.elationlighting.eu | info@elationlighting.eu